

STRATA PLAN EPS4147

LEVEL 1



SCALE 1:200 DISTANCES ARE IN METRES

THE INTENDED PLOT SCALE OF THIS PLAN IS 280 mm IN WIDTH BY 432 mm IN HEIGHT (B SIZE) WHEN PLOTTED AT A SCALE OF 1:200.

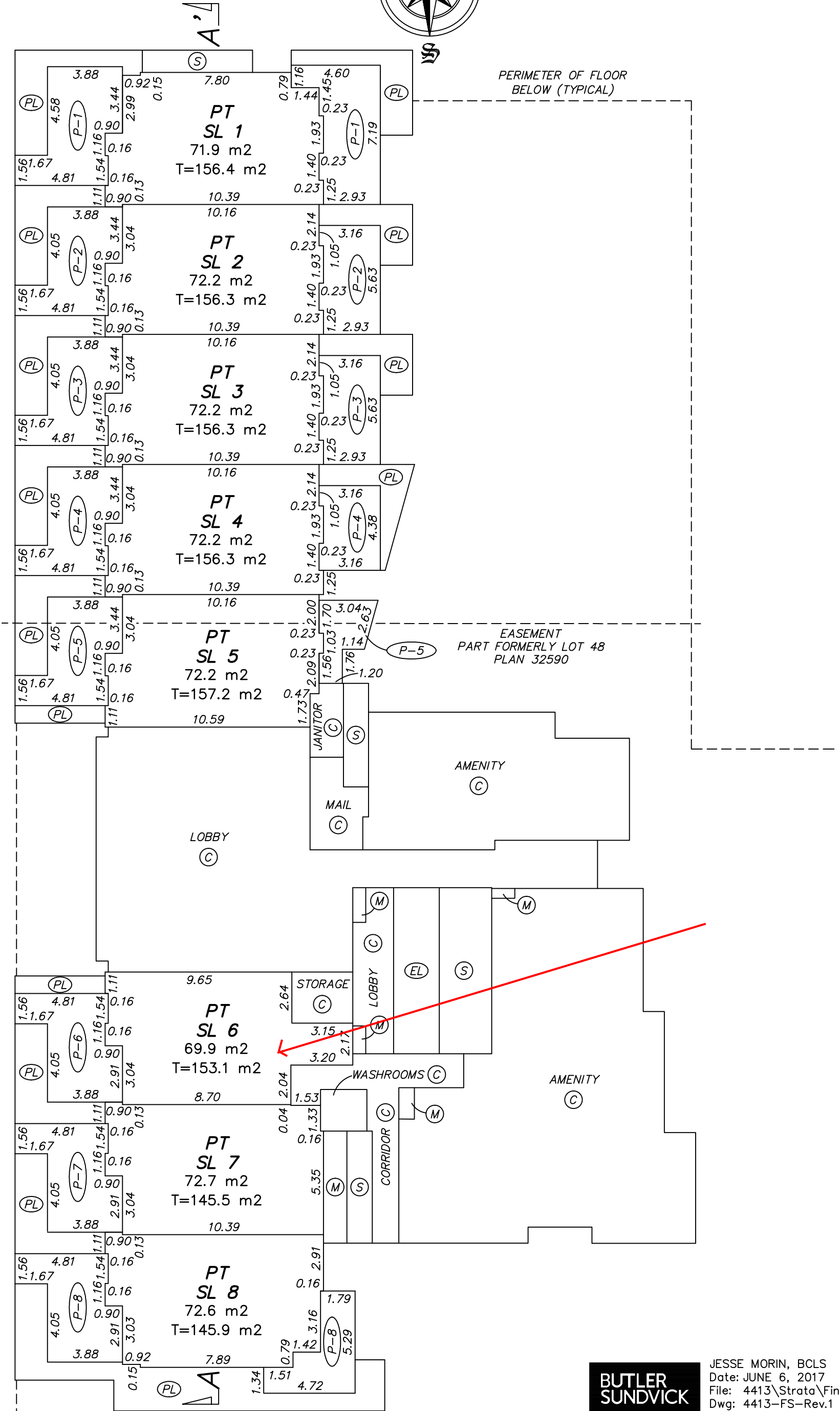

JESSE MORIN, BCLS
Date: JUNE 6, 2017
File: 4413\Strata\Final
Dwg: 4413-FS-Rev.1

LEVEL 2



SCALE 1:200 DISTANCES ARE IN METRES

THE INTENDED PLOT SCALE OF THIS PLAN IS 280 mm IN WIDTH BY 432 mm IN HEIGHT (B SIZE) WHEN PLOTTED AT A SCALE OF 1:200.

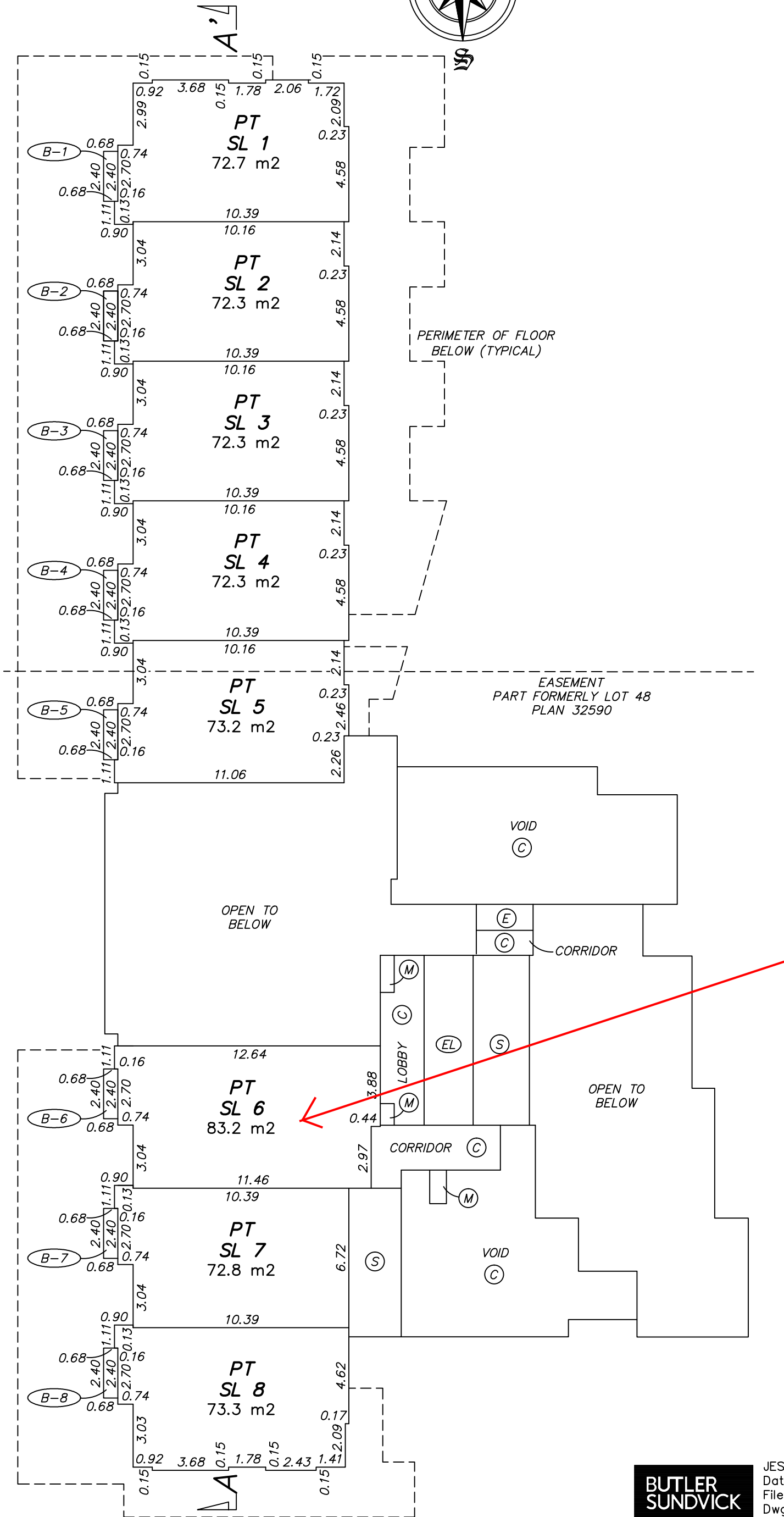

JESSE MORIN, BCLS
Date: JUNE 6, 2017
File: 4413\Strata\Final
Dwg: 4413-FS-Rev.1

**SURVEY PLAN CERTIFICATION
PROVINCE OF BRITISH COLUMBIA**

By incorporating your electronic signature into this form you are also incorporating your electronic signature into the attached plan and you
(a) represent that you are a subscriber and that you have incorporated your electronic signature to the attached electronic plan in accordance with section 168.73 (3) of the Land Title Act, RSBC 1996 c.250; and
(b) certify the matters set out in section 168.73 (4) of the Land Title Act,
Each term used in this representation and certification is to be given the meaning ascribed to it in part 10.1 of the Land Title Act.

1. BC LAND SURVEYOR: (Name, address, phone number)

Surveyor General Certification [For Surveyor General Use Only]

2. PLAN IDENTIFICATION: Control Number:
Plan Number:
This original plan number assignment was done under Commission #: LTO Document Reference:

3. CERTIFICATION: Form 9 Explanatory Plan Form 9A

The field survey was completed on: (YYYY/Month/DD) The checklist was filed under ECR#:
The plan was completed and checked on: (YYYY/Month/DD)
I am a British Columbia land surveyor and certify that
this plan was completed and checked on: (YYYY/Month/DD)
that the checklist was filed under ECR#:
and that the plan is correct in accordance with Land Title Office records.

I am a British Columbia land surveyor and certify that the buildings included in this strata plan have not been previously occupied as of (YYYY/Month/DD) None Strata Form S

None Strata Form U1 Strata Form U1/U2

I am a British Columbia land surveyor and certify that the buildings shown on this strata plan are within the external boundaries of the land that is the subject of the strata plan
Certification Date: (YYYY/Month/DD)

I am a British Columbia land surveyor and certify:

1. That the buildings shown on this strata plan are within the external boundaries of the land that is the subject of the strata plan subject to clause 2 of this endorsement
2. That certain parts of the buildings are not within the external boundaries but appropriate and necessary easements of other interests are registered as set out in section 244 (1)(f) of the Strata Property Act.

Registered Charge Number(s):

Certification Date: (YYYY/Month/DD)

Arterial Highway I am a British Columbia land surveyor and certify that I am authorized by the Minister of Transportation and Infrastructure under section 44.1 of the Transportation Act to show certain lands identified on this plan dedicated as Arterial Highway.

Remainder Parcel (Airspace) I am a British Columbia Land Surveyor and certify that no portion of the parcels or dedications created on this plan overlap vertically, that is, lie above or below any portion of the Air Space parcels on Air Space Plan

4. ALTERATION: LTO Document Reference:

This is an alteration to a previous version of this plan identified by control number:

DESCRIPTION OF ALTERATION: SEE SCHEDULE

**STRATA PLAN OF LOT A DISTRICT LOT 152 GROUP 1
NEW WESTMINSTER DISTRICT PLAN EPP30560**

STRATA PLAN EPS4147

CITY OF BURNABY
BCGS 92G.026

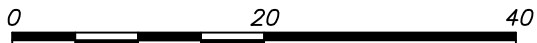

SCALE 1:600 DISTANCES ARE IN METRES

THE INTENDED PLOT SCALE OF THIS PLAN IS 280 mm IN WIDTH BY 432 mm IN HEIGHT (B SIZE) WHEN PLOTTED AT A SCALE OF 1:600.



85H0784
Datum: NAD83(CSRS) 4.0.0.BC.1.GVRD
UTM Zone 10
UTM Northing: 5452668.327 m
UTM Easting: 500430.812 m
Station Combined Factor: 0.9995826
Estimated horizontal positional accuracy Northing: 0.008 m
Estimated horizontal positional accuracy Easting: 0.008 m

INTEGRATED SURVEY AREA NO.25
CITY OF BURNABY NAD83(CSRS)

GRID BEARINGS ARE DERIVED FROM OBSERVATIONS AND ARE REFERRED TO CENTRAL MERIDIAN OF UTM ZONE 10.

THE UTM COORDINATES AND ESTIMATED HORIZONTAL POSITIONAL ACCURACY ACHIEVED ARE DERIVED FROM OBSERVATIONS TO GEODETIC CONTROL MONUMENTS 85H0784 AND 87H3242.

THIS PLAN SHOWS HORIZONTAL GROUND-LEVEL DISTANCES, UNLESS OTHERWISE SPECIFIED. TO COMPUTE GRID DISTANCES, MULTIPLY GROUND-LEVEL DISTANCES BY THE AVERAGE COMBINED FACTOR OF 0.9995826.
THE AVERAGE COMBINED FACTOR HAS BEEN DETERMINED BASED ON AN ELLIPSOIDAL ELEVATION OF 111.649 METRES.

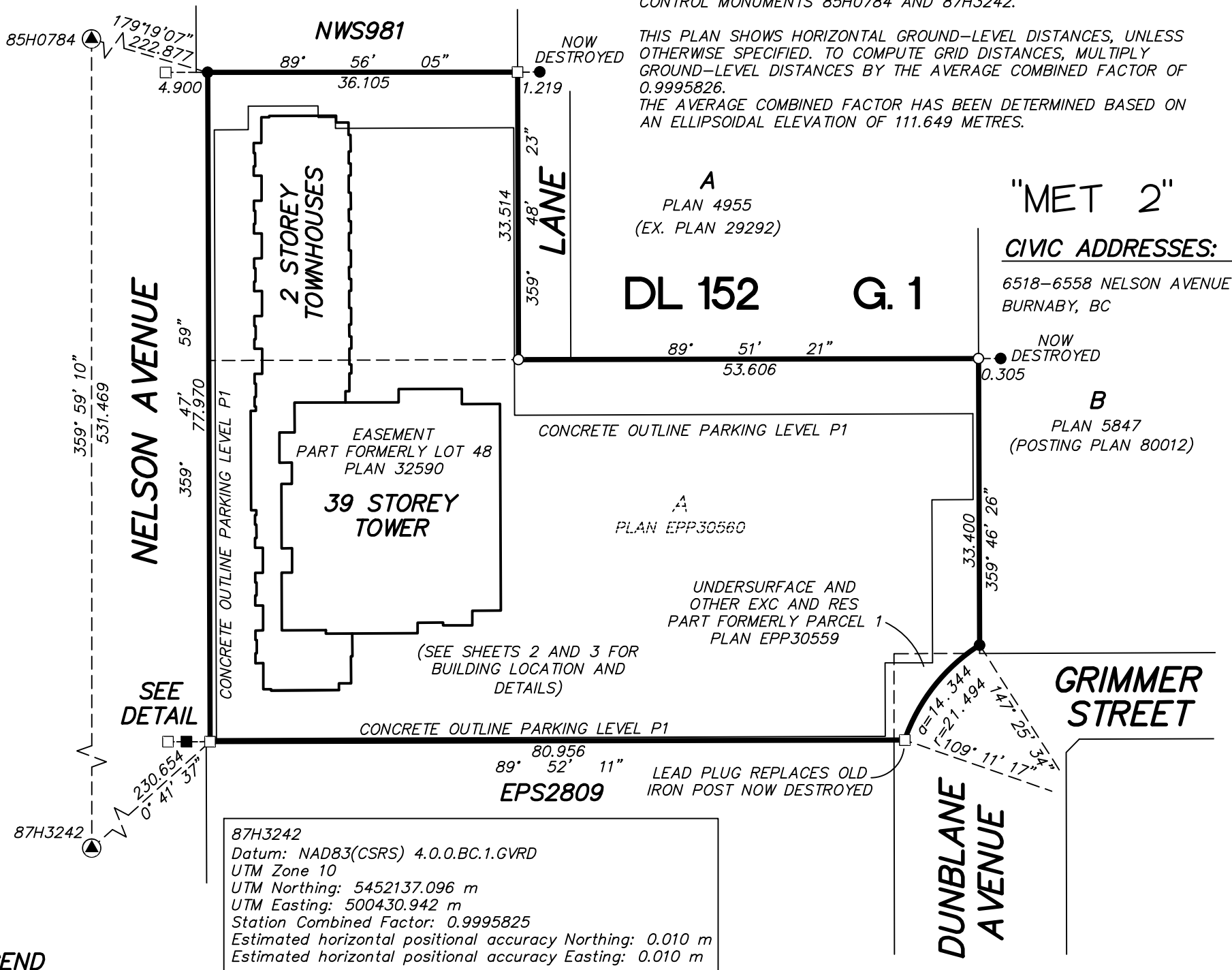

"MET 2"
CIVIC ADDRESSES:
6518-6558 NELSON AVENUE
BURNABY, BC

B
PLAN 5847
(POSTING PLAN 80012)

87H3242
Datum: NAD83(CSRS) 4.0.0.BC.1.GVRD
UTM Zone 10
UTM Northing: 5452137.096 m
UTM Easting: 500430.942 m
Station Combined Factor: 0.9995825
Estimated horizontal positional accuracy Northing: 0.010 m
Estimated horizontal positional accuracy Easting: 0.010 m

LEGEND

- | | | |
|----------------|--------|---|
| FOUND | PLACED | |
| ▲ | □ | DENOTES CONTROL MONUMENT |
| ■ | ○ | DENOTES LEAD PLUG |
| ● | ○ | DENOTES IRON POST |
| m ² | | DENOTES SQUARE METRES |
| SL | | DENOTES STRATA LOT |
| I/F | | DENOTES INSIDE FACE OF CONCRETE WALL |
| (C) | | DENOTES COMMON PROPERTY |
| (E) | | DENOTES ELECTRICAL ROOM BEING COMMON PROPERTY |
| (M) | | DENOTES MECHANICAL ROOM BEING COMMON PROPERTY |
| (V) | | DENOTES VESTIBULE BEING COMMON PROPERTY |
| (S) | | DENOTES STAIRS BEING COMMON PROPERTY |
| (EL) | | DENOTES ELEVATOR BEING COMMON PROPERTY |
| (PL) | | DENOTES PLANTER BEING COMMON PROPERTY |
| (P-1) | | DENOTES PATIO BEING LIMITED COMMON PROPERTY FOR THE EXCLUSIVE USE OF STRATA LOT 1 (TYPICAL) |
| (RD-1) | | DENOTES ROOF DECK BEING LIMITED COMMON PROPERTY FOR THE EXCLUSIVE USE OF STRATA LOT 1 (TYPICAL) |
| (B-17) | | DENOTES BALCONY BEING LIMITED COMMON PROPERTY FOR THE EXCLUSIVE USE OF STRATA LOT 17 (TYPICAL) |
- THE BUILDING INCLUDED IN THIS STRATA PLAN HAS NOT BEEN PREVIOUSLY OCCUPIED
- THE BUILDING SHOWN HEREON IS WITHIN THE EXTERNAL BOUNDARIES OF THE LAND THAT IS THE SUBJECT OF THE STRATA PLAN

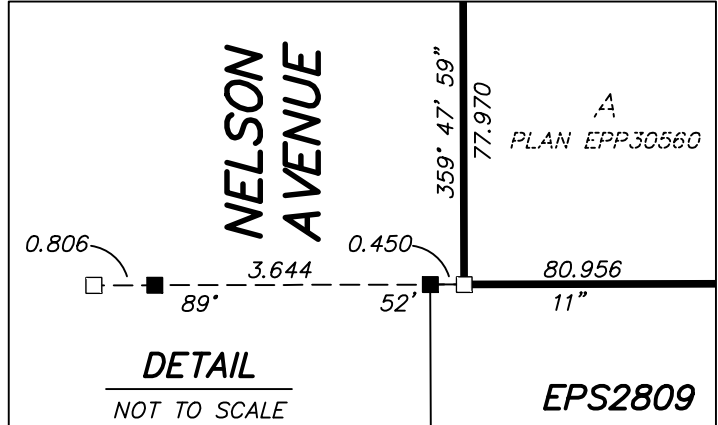

NOTES:

NOTICE UNDER SECTION 68 OF THE STRATA PROPERTY ACT. STRATA LOT BOUNDARIES ARE DEFINED THE EXTERIOR FACE OF EXTERIOR WALLS, THE EXTERIOR FACE OF INTERIOR WALLS ADJOINING COMMON AREAS, AND TO THE CENTRE LINE OF DEMISING WALLS BETWEEN STRATA LOTS.

THE 4th, 13th, 14th, 24th, AND 34th FLOORS HAVE BEEN ELIMINATED FROM CONSECUTIVE FLOOR NUMBERING

THE FIELD SURVEY REPRESENTED BY THIS PLAN WAS COMPLETED ON THE 1st DAY OF JUNE, 2017
JESSE MORIN, BCLS (880)
ECR#: 199442

**BUTLER
SUNDEVICK**
4 - 19089 94th Ave
Surrey, BC V4N 3S4
www.butlersundevick.ca
Tel. 604-513-9611
File: 4413\Strata\Final
Dwg: 4413-FS-Rev.1

THIS PLAN LIES WITHIN THE GREATER VANCOUVER REGIONAL DISTRICT

BUILDING LOCATION AND DETAILS

STRATA PLAN EPS4147

0 5 10 15 20

SCALE 1 : 250 DISTANCES ARE METRIC

THE INTENDED PLOT SCALE OF THIS PLAN IS 280 mm IN WIDTH BY 432 mm IN HEIGHT (B SIZE) WHEN PLOTTED AT A SCALE OF 1:250.

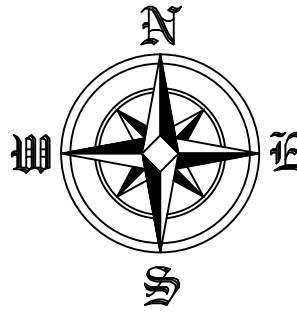

NELSON AVENUE

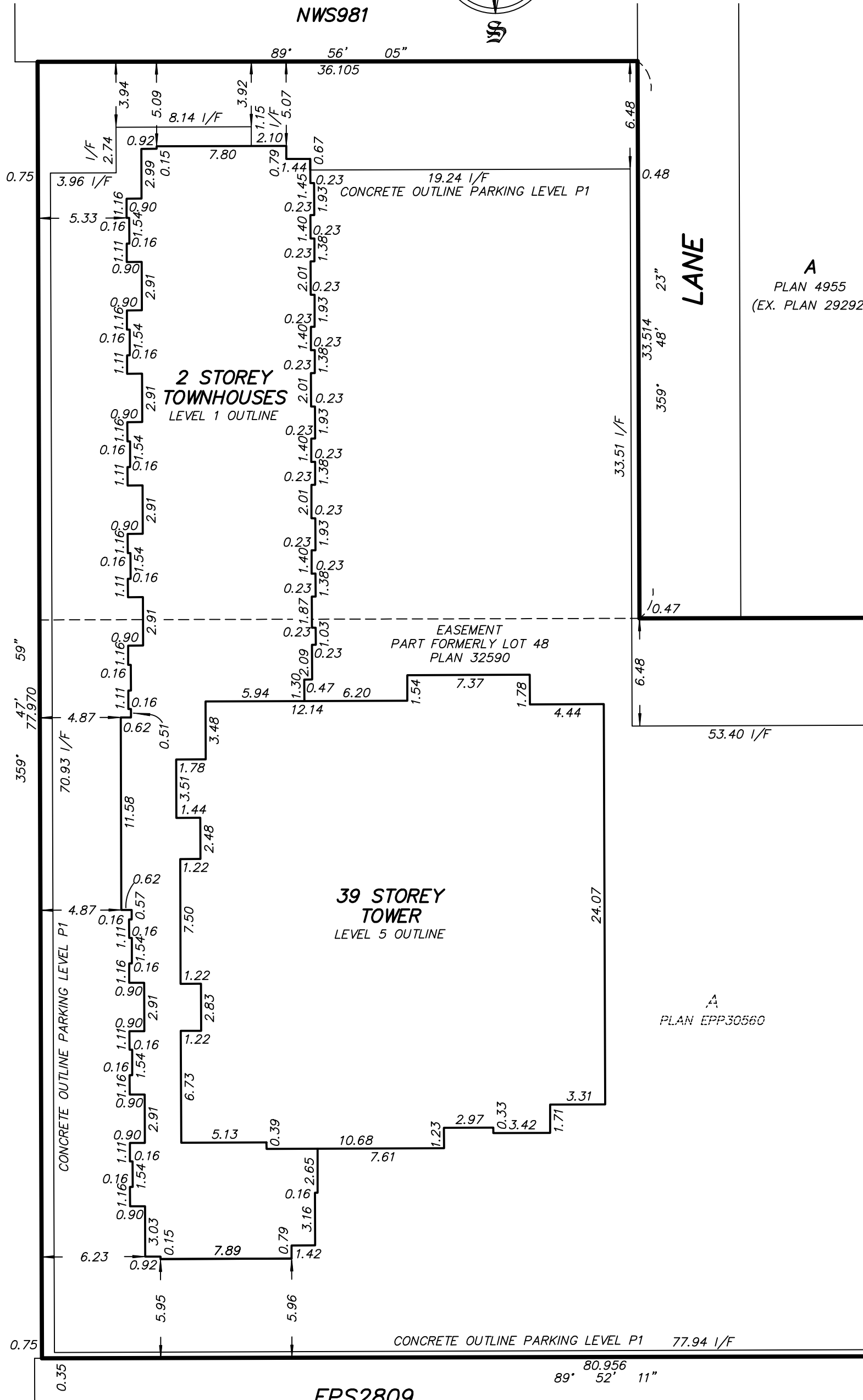

LANE

A
PLAN 4955
(EX. PLAN 29292)

A
PLAN EPP30560

(SEE SHEET 3 FOR CONTINUATION)

EPS2809



JESSE MORIN, BCLS
Date: JUNE 6, 2017
File: 4413\Strata\Final
Dwg: 4413-FS-Rev.1

BUILDING LOCATION AND DETAILS

STRATA PLAN EPS4147

0 5 10 15 20



SCALE 1 : 250 DISTANCES ARE METRIC

THE INTENDED PLOT SCALE OF THIS PLAN IS 280 mm IN WIDTH BY 432 mm IN HEIGHT (B SIZE) WHEN PLOTTED AT A SCALE OF 1:250.

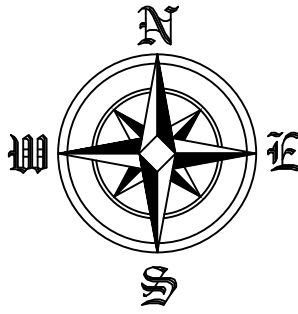

A
PLAN 4955
(EX. PLAN 29292)

B
PLAN 5847
(POSTING PLAN 80012)

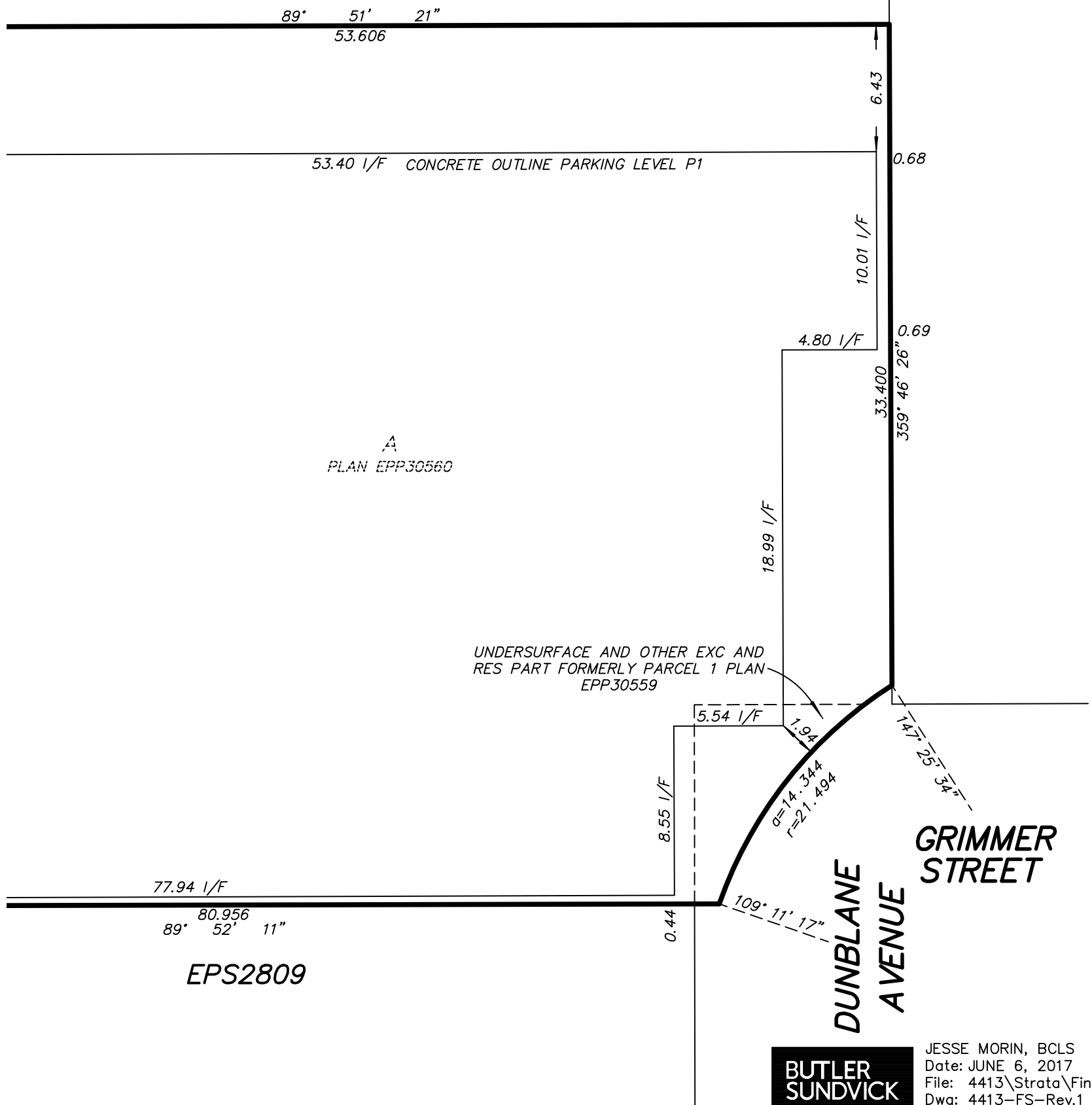

(SEE SHEET 2 FOR CONTINUATION)

PARKING LEVEL P4

STRATA PLAN EPS4147

0 5 10 15 20



SCALE 1 : 250 DISTANCES ARE METRIC

THE INTENDED PLOT SCALE OF THIS PLAN IS 280 mm IN WIDTH BY 432 mm IN HEIGHT (B SIZE) WHEN PLOTTED AT A SCALE OF 1:250.

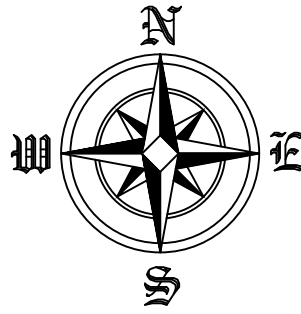

A' A

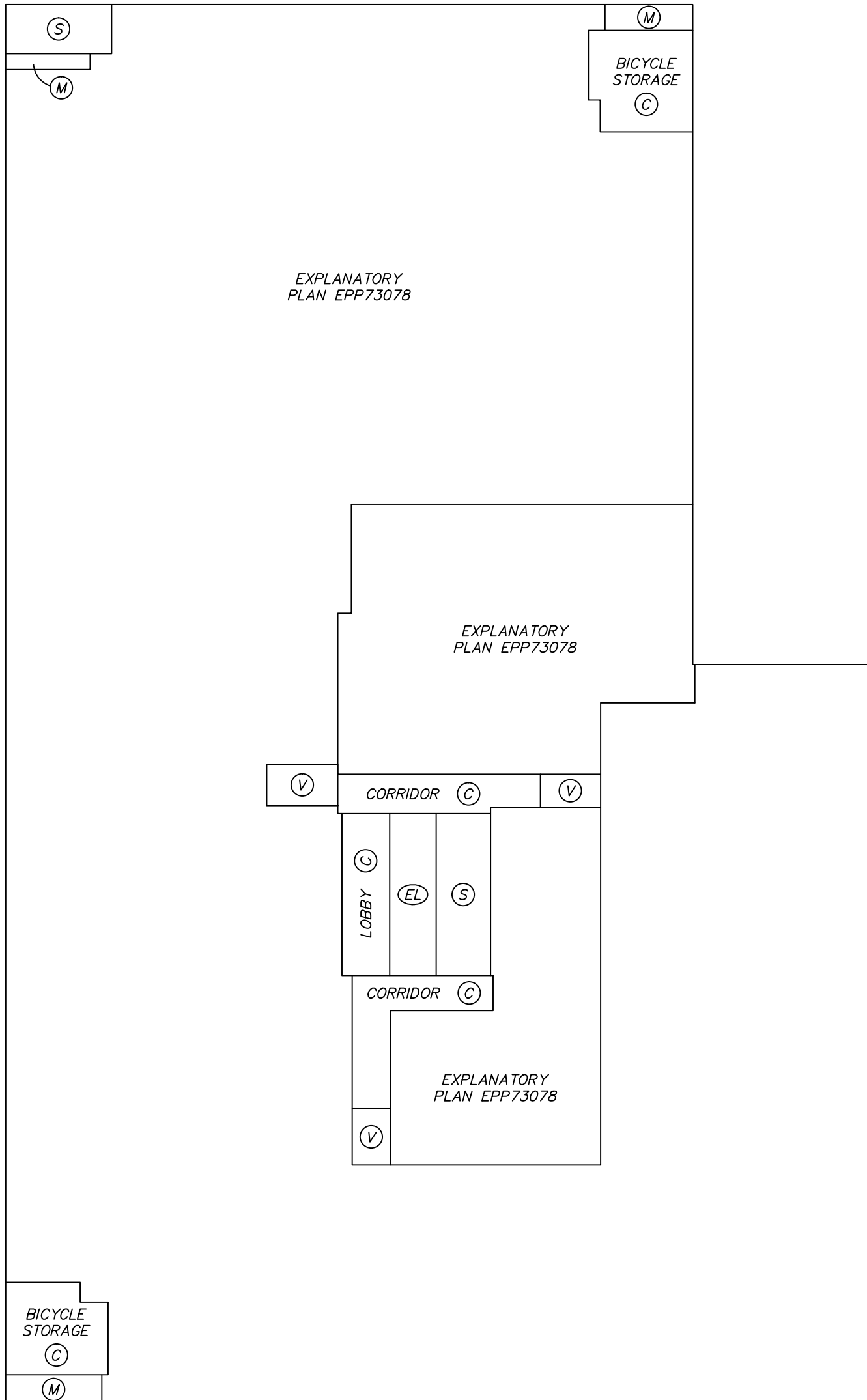

(SEE SHEET 5 FOR CONTINUATION)

A A

PARKING LEVEL P4

STRATA PLAN EPS4147

0 5 10 15 20



SCALE 1 : 250 DISTANCES ARE METRIC

THE INTENDED PLOT SCALE OF THIS PLAN IS 280 mm IN WIDTH BY 432 mm IN HEIGHT (B SIZE) WHEN PLOTTED AT A SCALE OF 1:250.

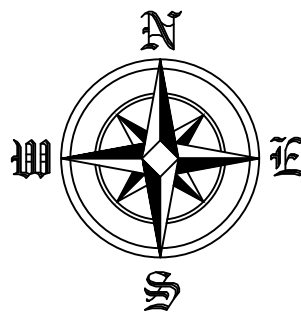

(SEE SHEET 4 FOR CONTINUATION)

EXPLANATORY
PLAN EPP73078

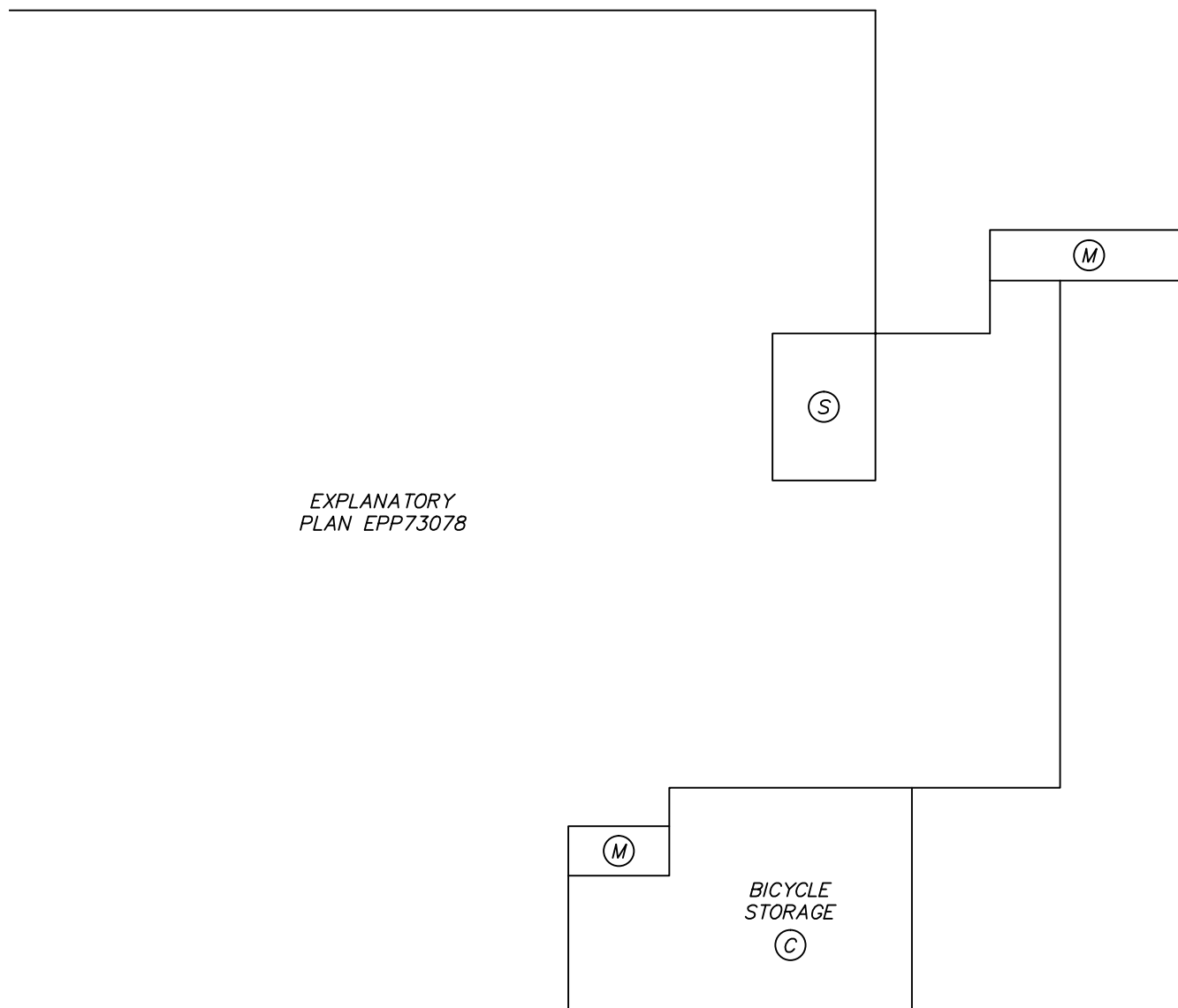

JESSE MORIN, BCLS
Date: JUNE 6, 2017
File: 4413\Strata\Final
Dwg: 4413-FS-Rev.1

PARKING LEVEL P3

0 5 10 15 20



SCALE 1 : 250 DISTANCES ARE METRIC

THE INTENDED PLOT SCALE OF THIS PLAN IS 280 mm IN WIDTH BY 432 mm IN HEIGHT (B SIZE) WHEN PLOTTED AT A SCALE OF 1:250.

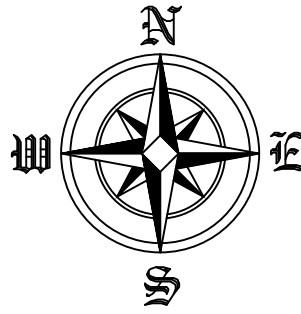

A' A

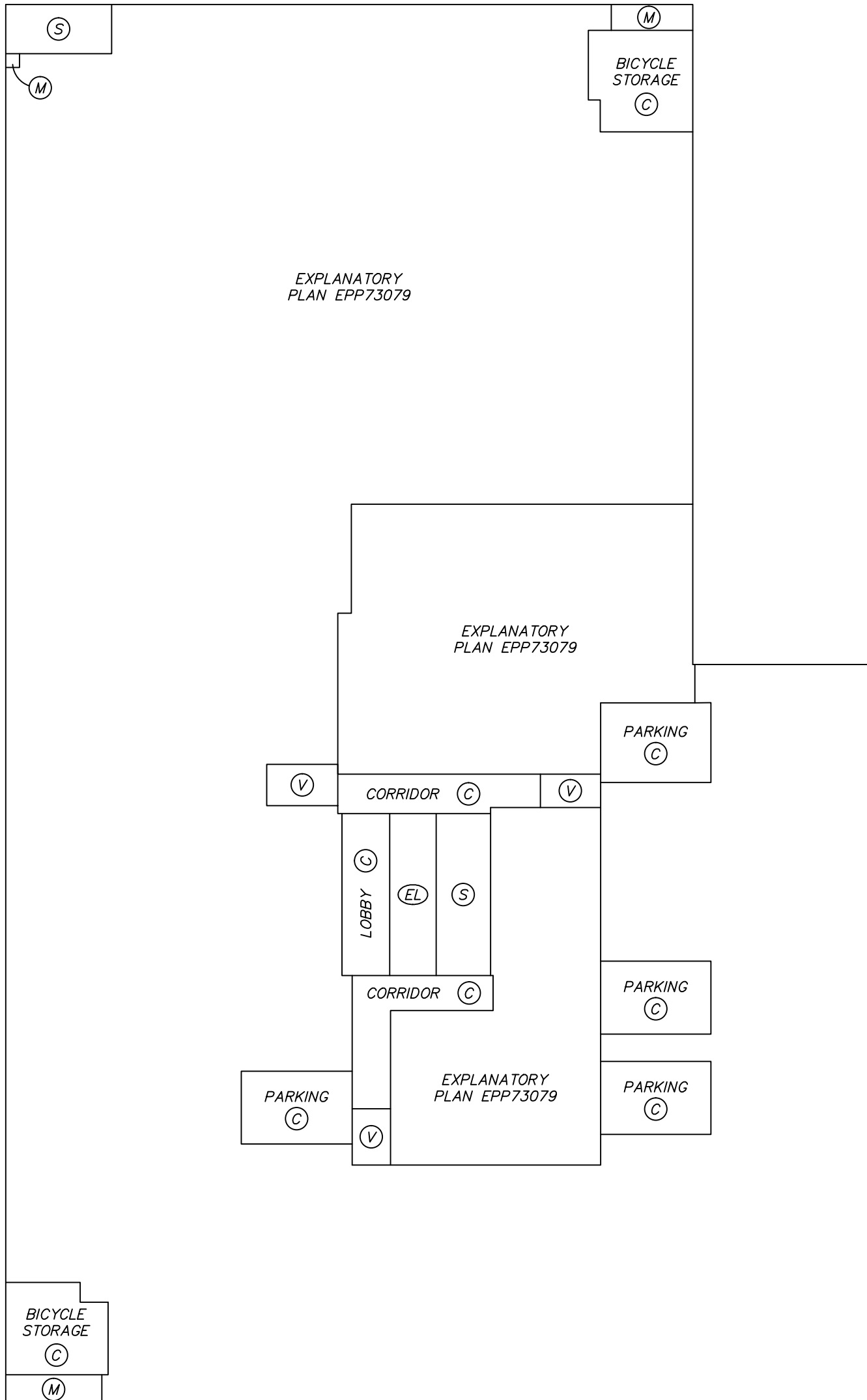

(SEE SHEET 7 FOR CONTINUATION)

A A

PARKING LEVEL P3

STRATA PLAN EPS4147

0 5 10 15 20



SCALE 1 : 250 DISTANCES ARE METRIC

THE INTENDED PLOT SCALE OF THIS PLAN IS 280 mm IN WIDTH BY 432 mm IN HEIGHT (B SIZE) WHEN PLOTTED AT A SCALE OF 1:250.

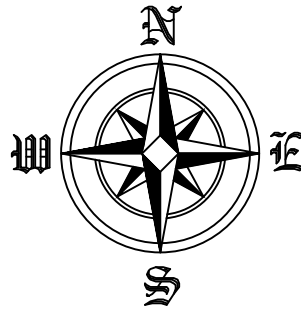

(SEE SHEET 6 FOR CONTINUATION)

EXPLANATORY
PLAN EPP73079

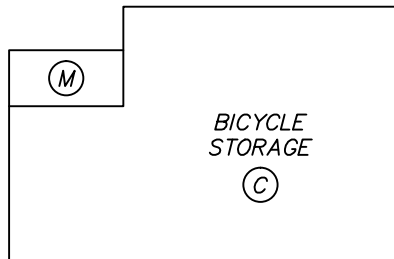
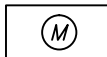
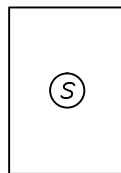

PARKING LEVEL P2

0 5 10 15 20



SCALE 1 : 250 DISTANCES ARE METRIC

THE INTENDED PLOT SCALE OF THIS PLAN IS 280 mm IN WIDTH BY 432 mm IN HEIGHT (B SIZE) WHEN PLOTTED AT A SCALE OF 1:250.

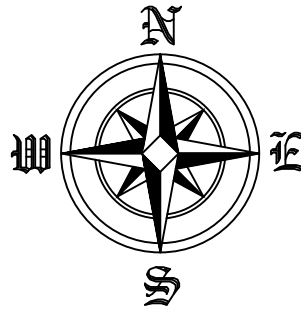

A' A

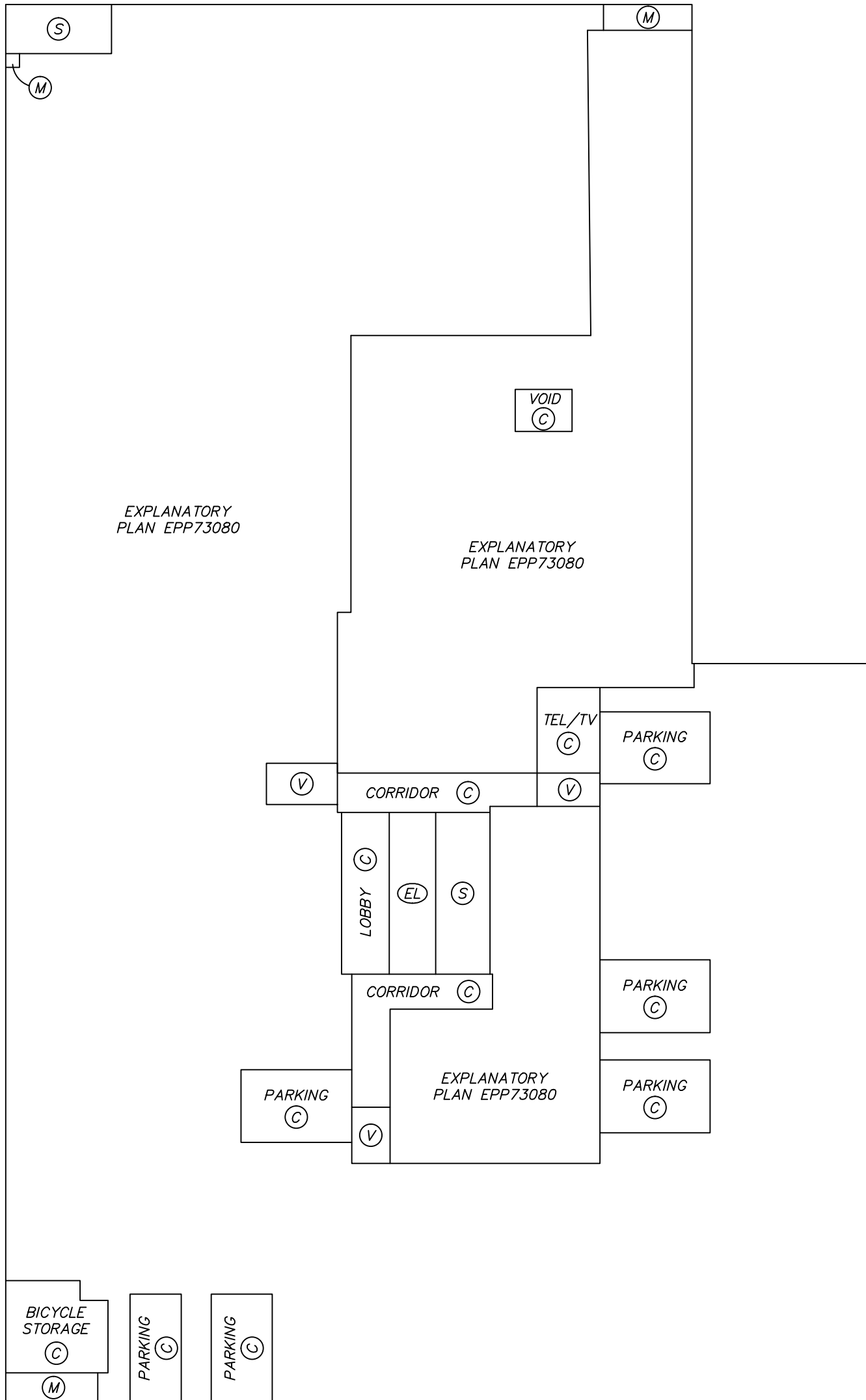

(SEE SHEET 9 FOR CONTINUATION)

A A

PARKING LEVEL P2

STRATA PLAN EPS4147

0 5 10 15 20



SCALE 1 : 250 DISTANCES ARE METRIC

THE INTENDED PLOT SCALE OF THIS PLAN IS 280 mm IN WIDTH BY 432 mm IN HEIGHT (B SIZE) WHEN PLOTTED AT A SCALE OF 1:250.

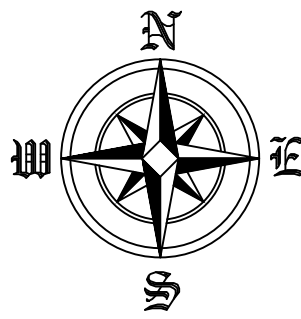

(SEE SHEET 8 FOR CONTINUATION)

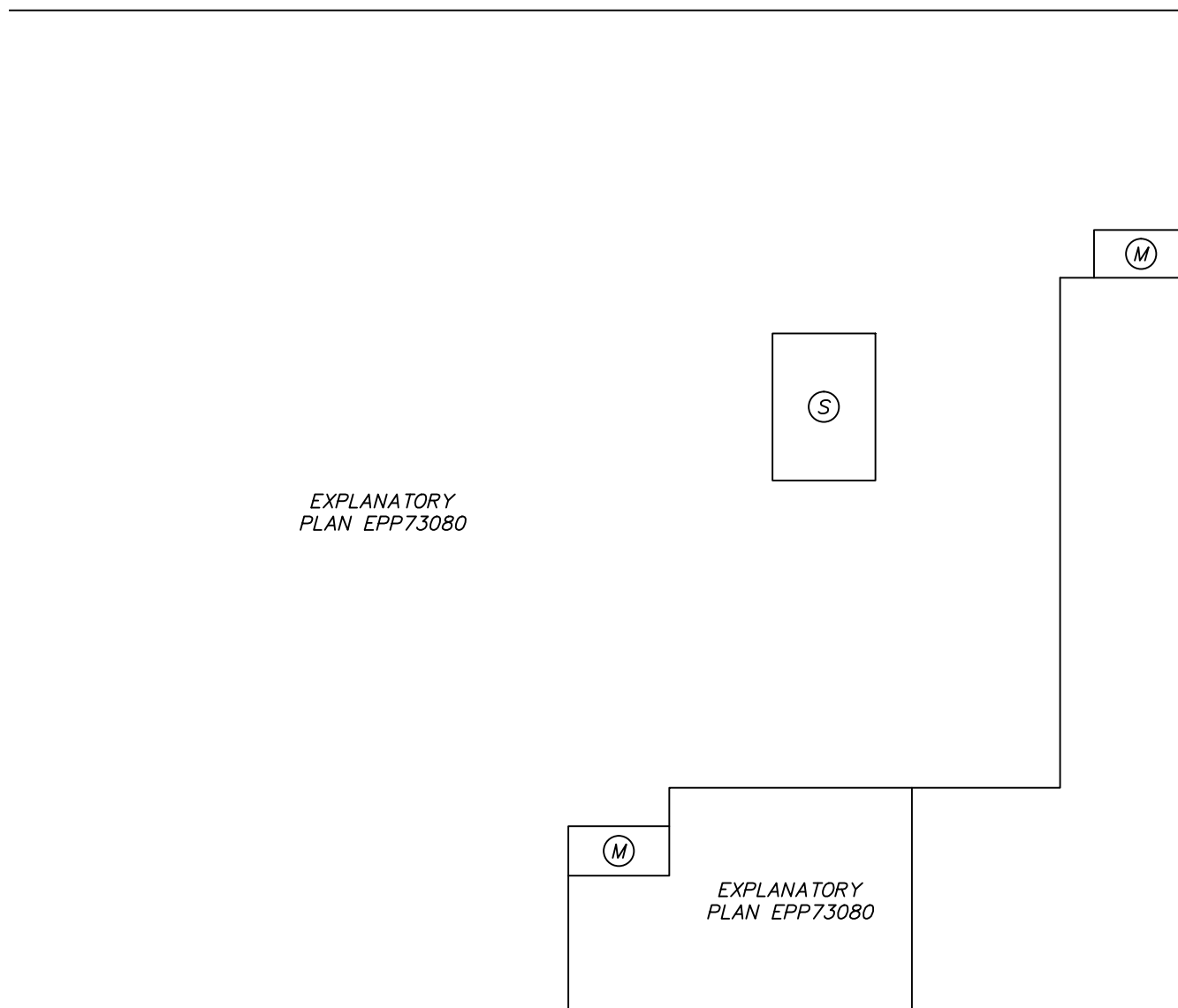

JESSE MORIN, BCLS
Date: JUNE 6, 2017
File: 4413\Strata\Final
Dwg: 4413-FS-Rev.1

PARKING LEVEL P1

0 5 10 15 20



SCALE 1 : 250 DISTANCES ARE METRIC

THE INTENDED PLOT SCALE OF THIS PLAN IS 280 mm IN WIDTH BY 432 mm IN HEIGHT (B SIZE) WHEN PLOTTED AT A SCALE OF 1:250.

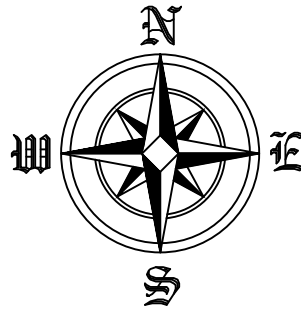

A' A

EXPLANATORY PLAN EPP73081

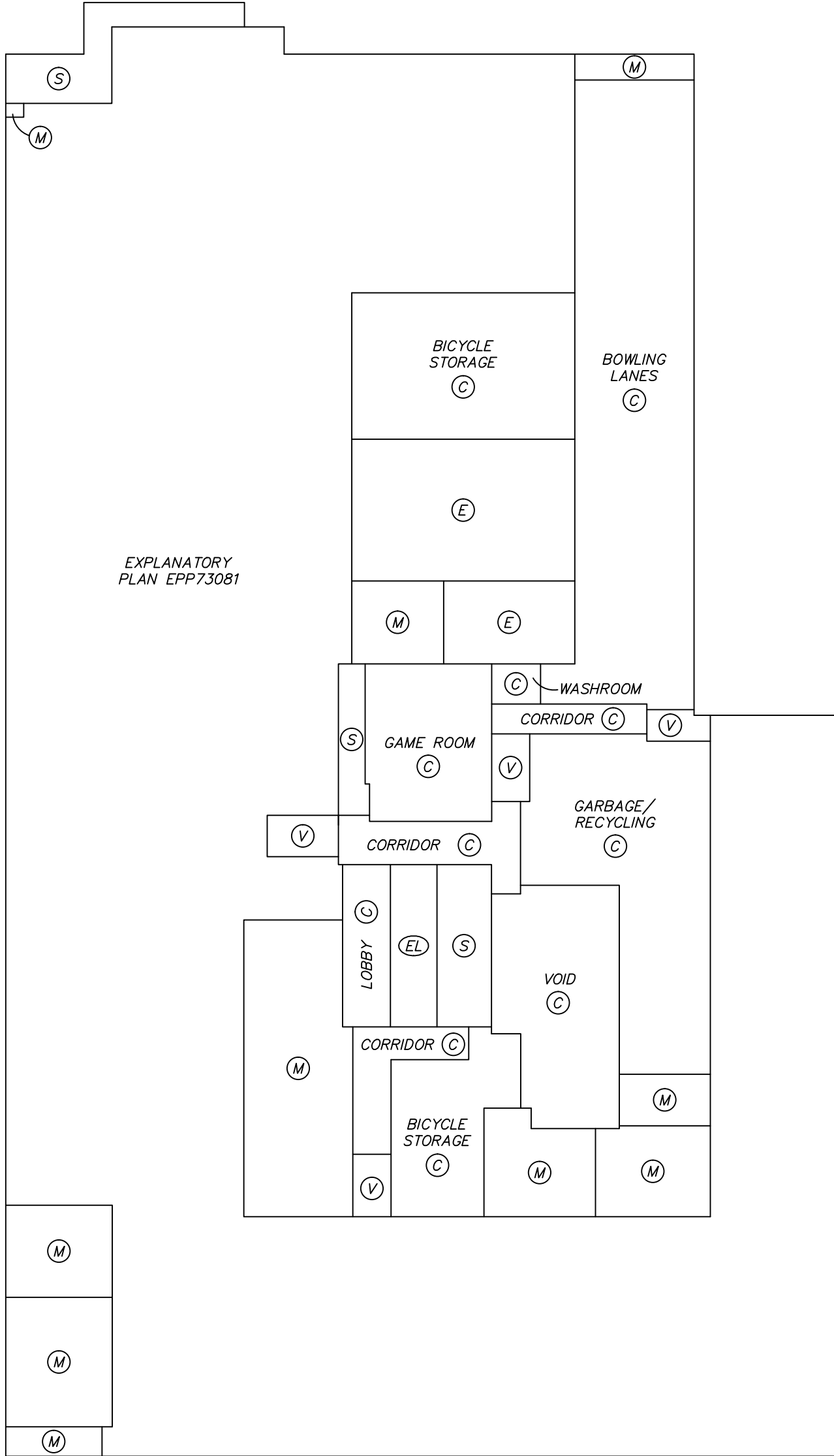

(SEE SHEET 11 FOR CONTINUATION)

A

PARKING LEVEL P1

STRATA PLAN EPS4147

0 5 10 15 20



SCALE 1 : 250 DISTANCES ARE METRIC

THE INTENDED PLOT SCALE OF THIS PLAN IS 280 mm IN WIDTH BY 432 mm IN HEIGHT (B SIZE) WHEN PLOTTED AT A SCALE OF 1:250.

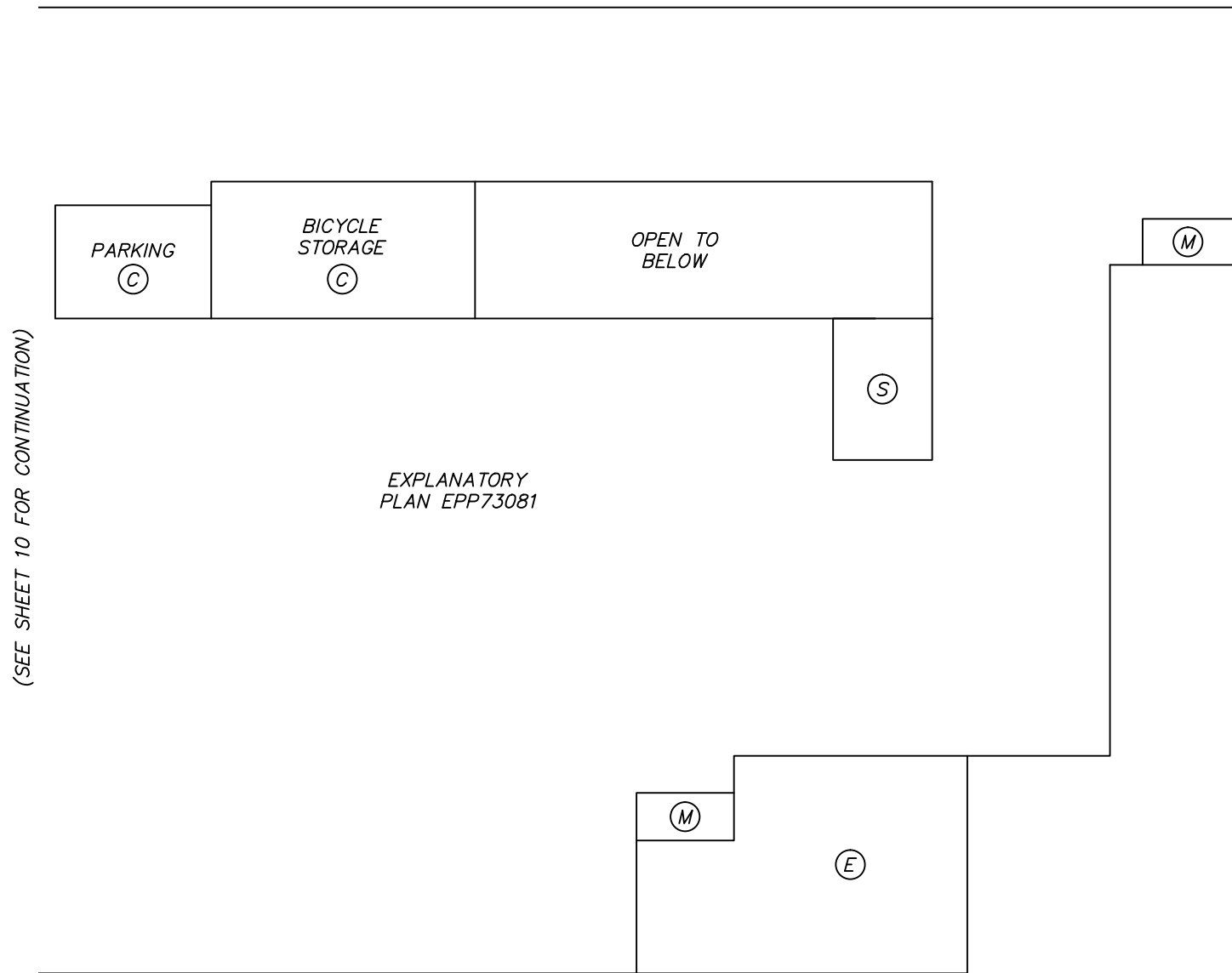
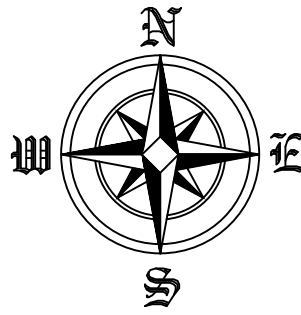

JESSE MORIN, BCLS
Date: JUNE 6, 2017
File: 4413\Strata\Final
Dwg: 4413-FS-Rev.1

STRATA PLAN EPS4147

LEVEL 1



SCALE 1:200 DISTANCES ARE IN METRES

THE INTENDED PLOT SCALE OF THIS PLAN IS 280 mm IN WIDTH BY 432 mm IN HEIGHT (B SIZE) WHEN PLOTTED AT A SCALE OF 1:200.

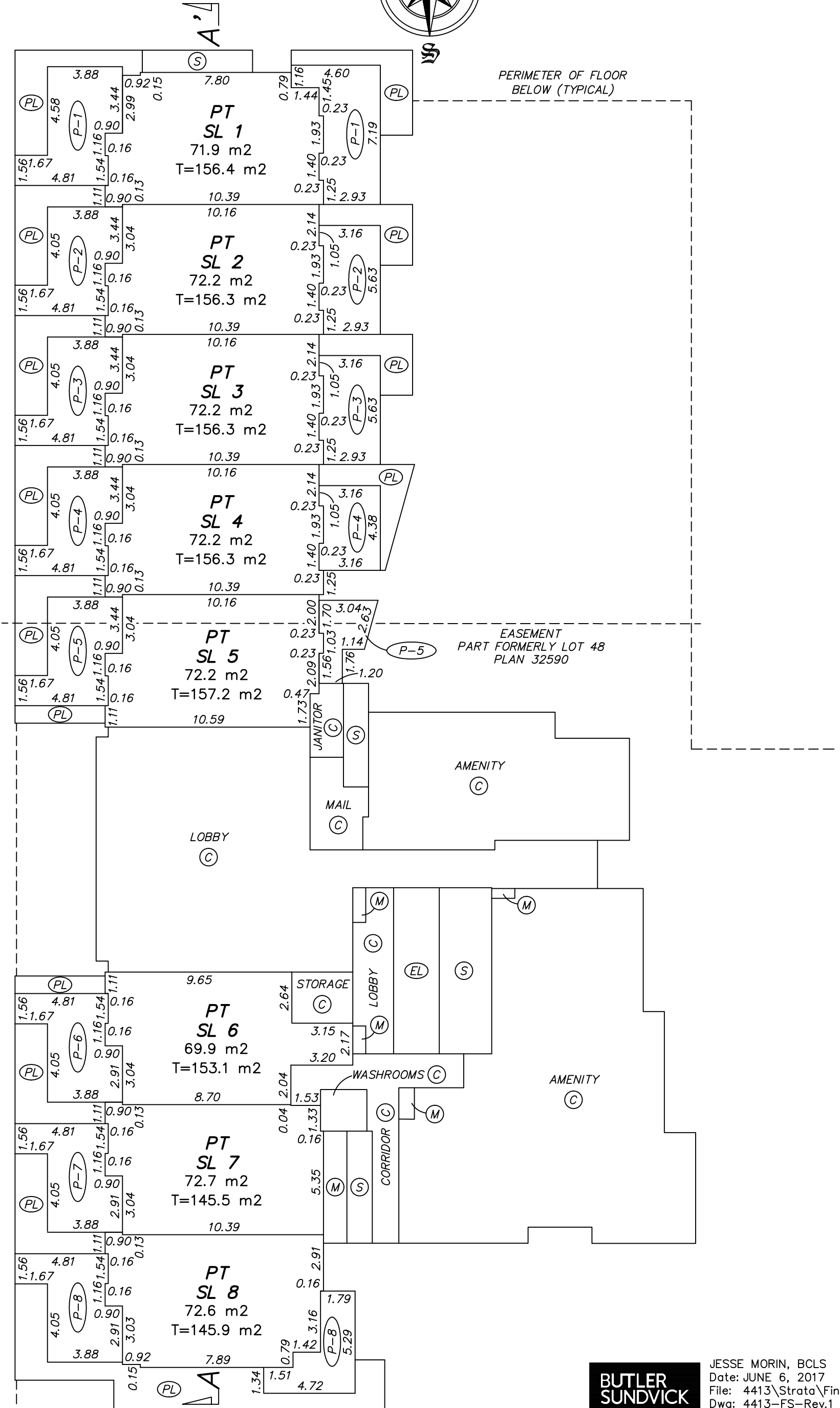

STRATA PLAN EPS4147

LEVEL 2



SCALE 1:200 DISTANCES ARE IN METRES

THE INTENDED PLOT SCALE OF THIS PLAN IS 280 mm IN WIDTH BY 432 mm IN HEIGHT (B SIZE) WHEN PLOTTED AT A SCALE OF 1:200.

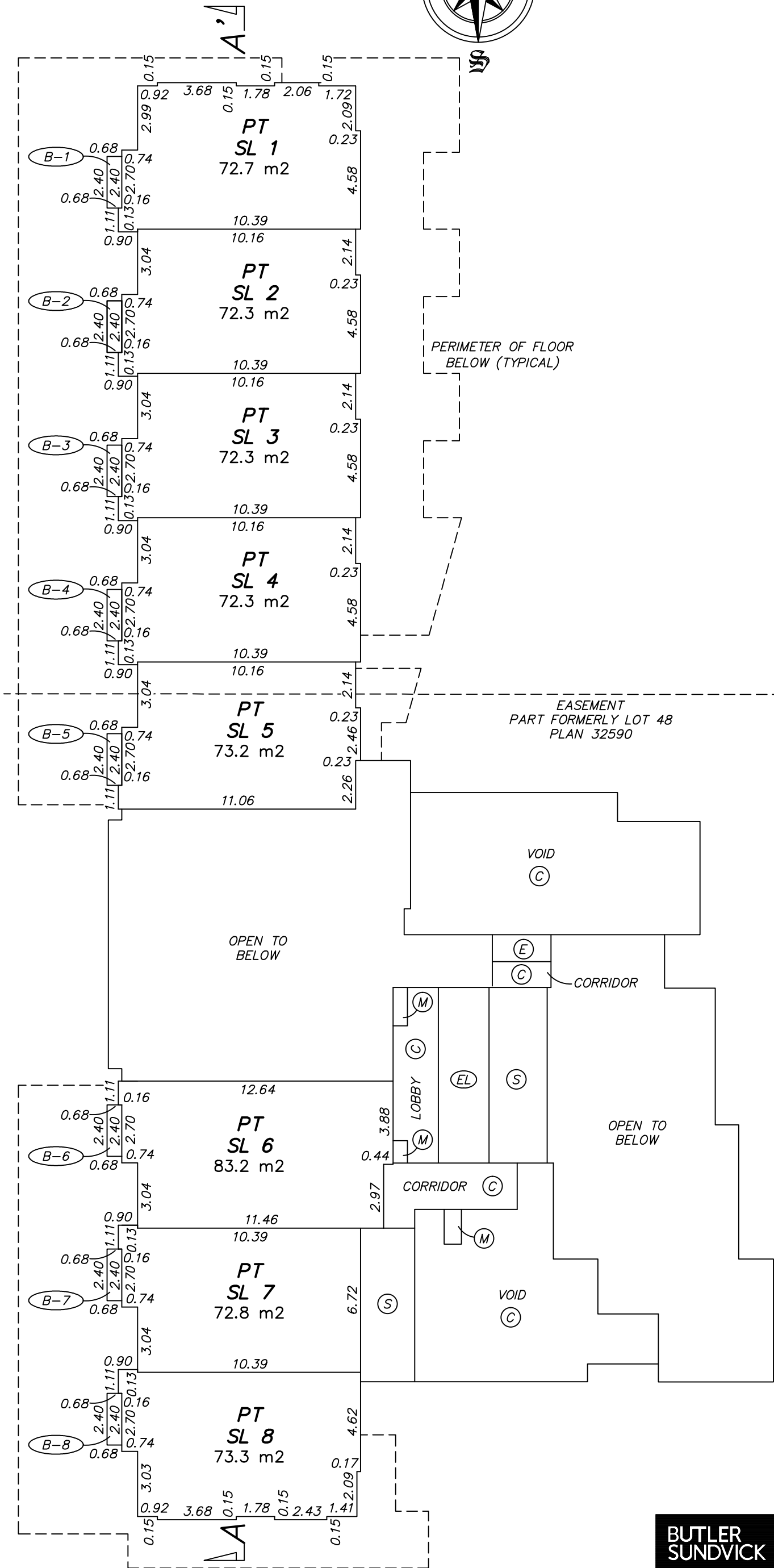
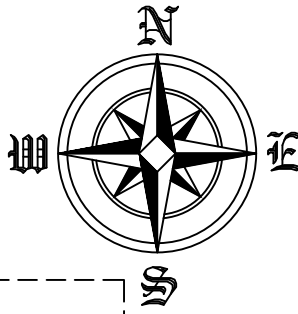

JESSE MORIN, BCLS
Date: JUNE 6, 2017
File: 4413\Strata\Final
Dwg: 4413-FS-Rev.1

LEVEL 3

STRATA PLAN EPS4147



SCALE 1:200 DISTANCES ARE IN METRES

THE INTENDED PLOT SCALE OF THIS PLAN IS 280 mm IN WIDTH BY 432 mm IN HEIGHT (B SIZE) WHEN PLOTTED AT A SCALE OF 1:200.

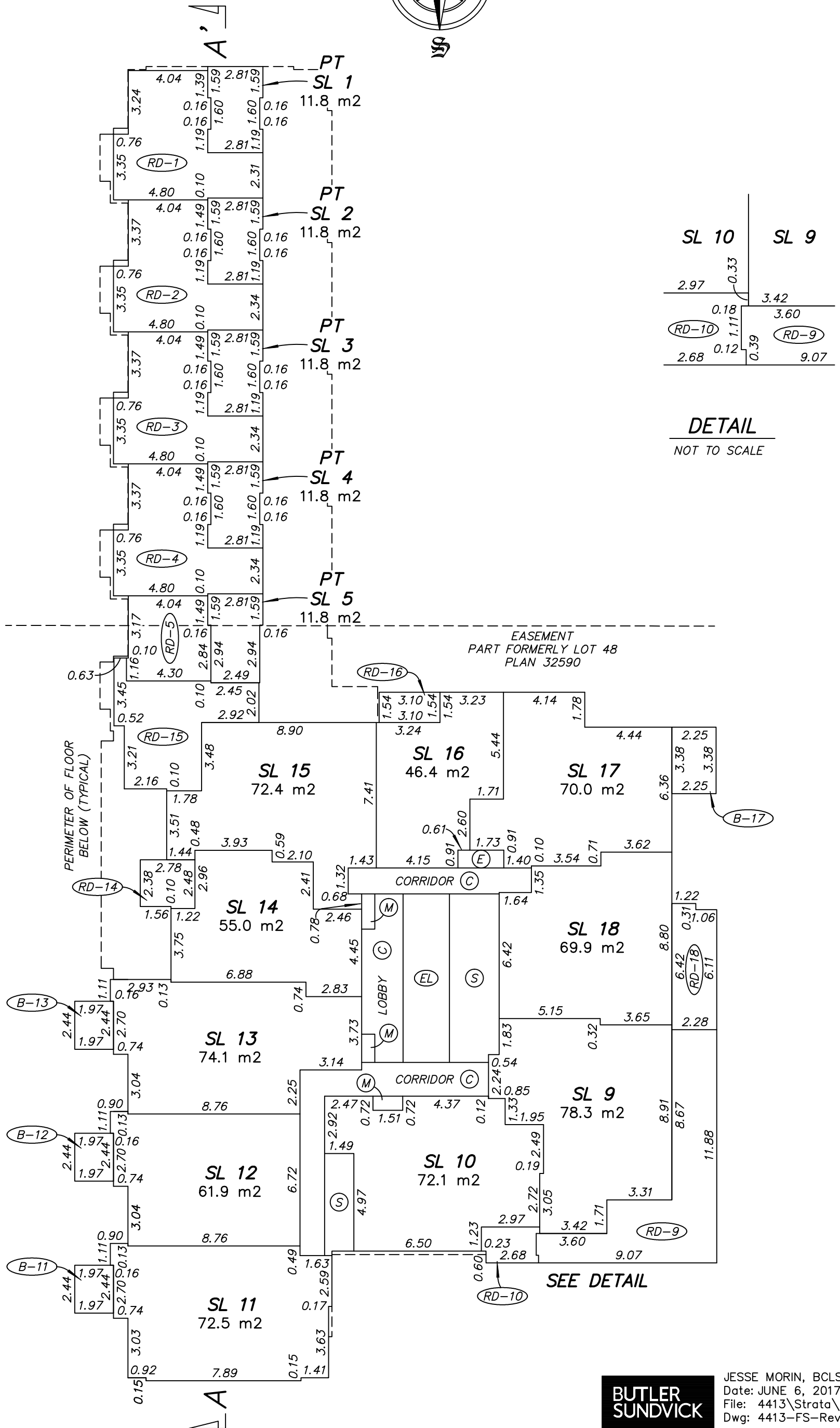
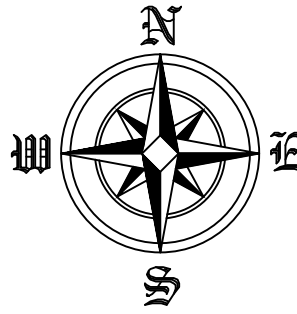

LEVEL 5

STRATA PLAN EPS4147

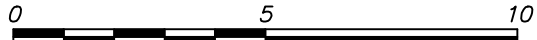

SCALE 1:150 DISTANCES ARE IN METRES

THE INTENDED PLOT SCALE OF THIS PLAN IS 280 mm IN WIDTH BY 432 mm IN HEIGHT (B SIZE) WHEN PLOTTED AT A SCALE OF 1:150.

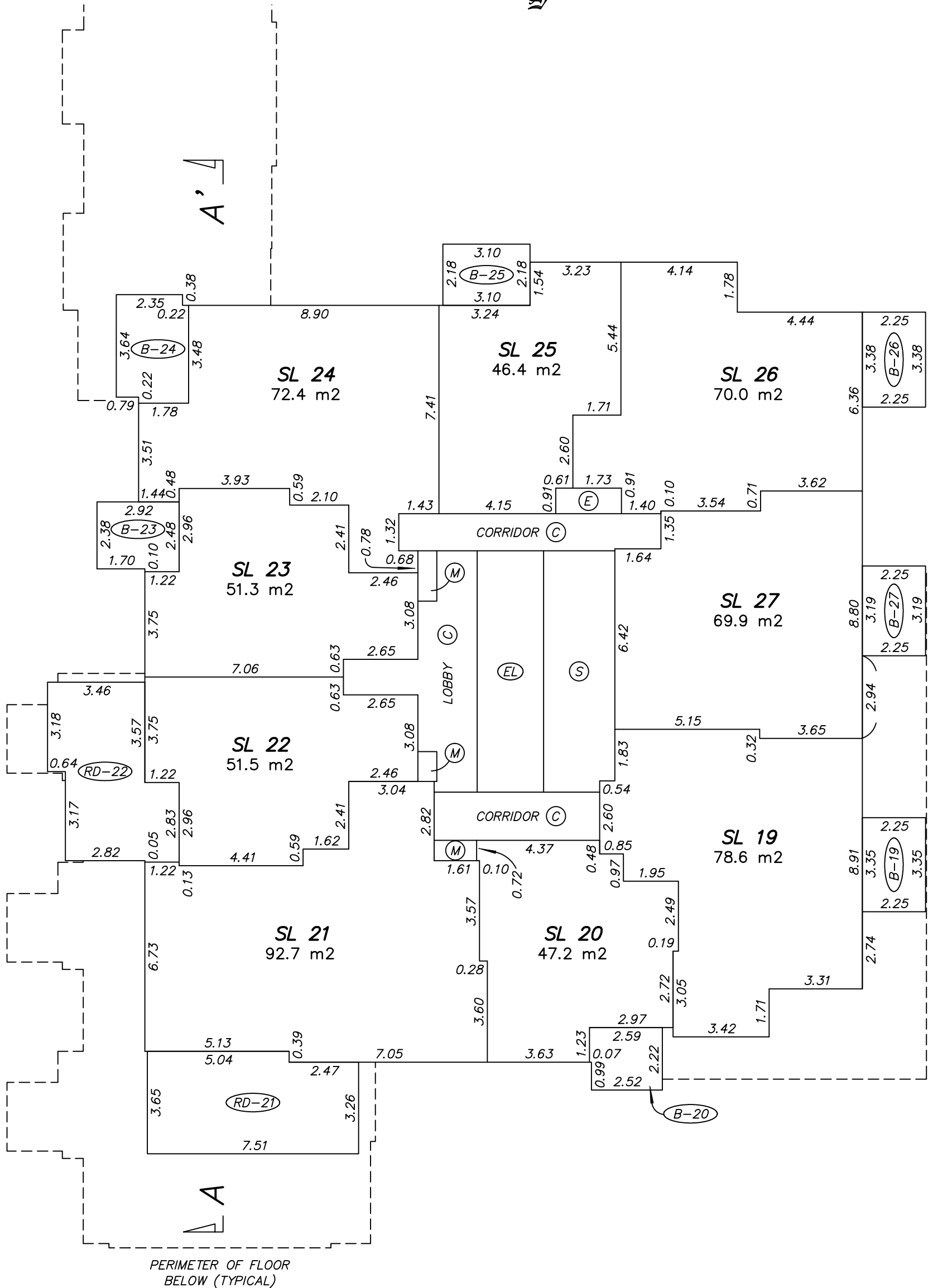
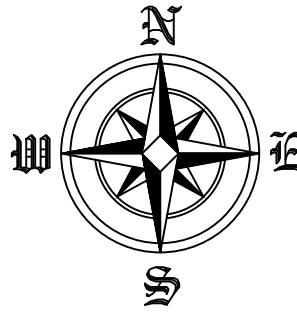

NOTE: THE 4th FLOOR HAS BEEN ELIMINATED FROM CONSECUTIVE FLOOR NUMBERING



JESSE MORIN, BCLS
Date: JUNE 6, 2017
File: 4413\Strata\Final
Dwg: 4413-FS-Rev.1

LEVEL 6

STRATA PLAN EPS4147

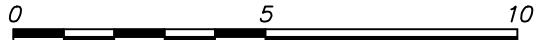

SCALE 1:150 DISTANCES ARE IN METRES

THE INTENDED PLOT SCALE OF THIS PLAN IS 280 mm IN WIDTH BY 432 mm IN HEIGHT (B SIZE) WHEN PLOTTED AT A SCALE OF 1:150.

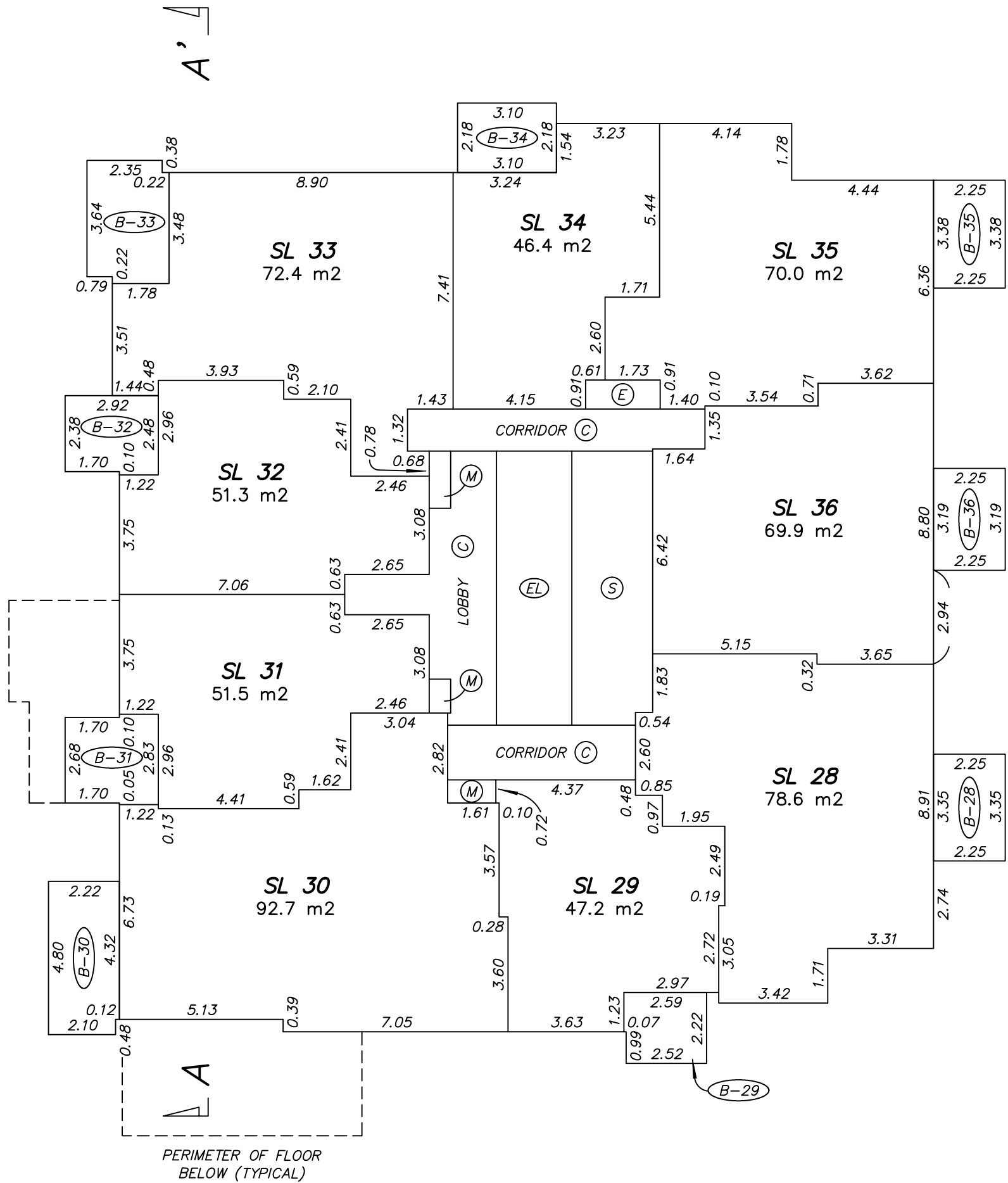

LEVEL 7

STRATA PLAN EPS4147

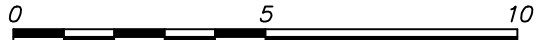

SCALE 1:150 DISTANCES ARE IN METRES

THE INTENDED PLOT SCALE OF THIS PLAN IS 280 mm IN WIDTH BY 432 mm IN HEIGHT (B SIZE) WHEN PLOTTED AT A SCALE OF 1:150.

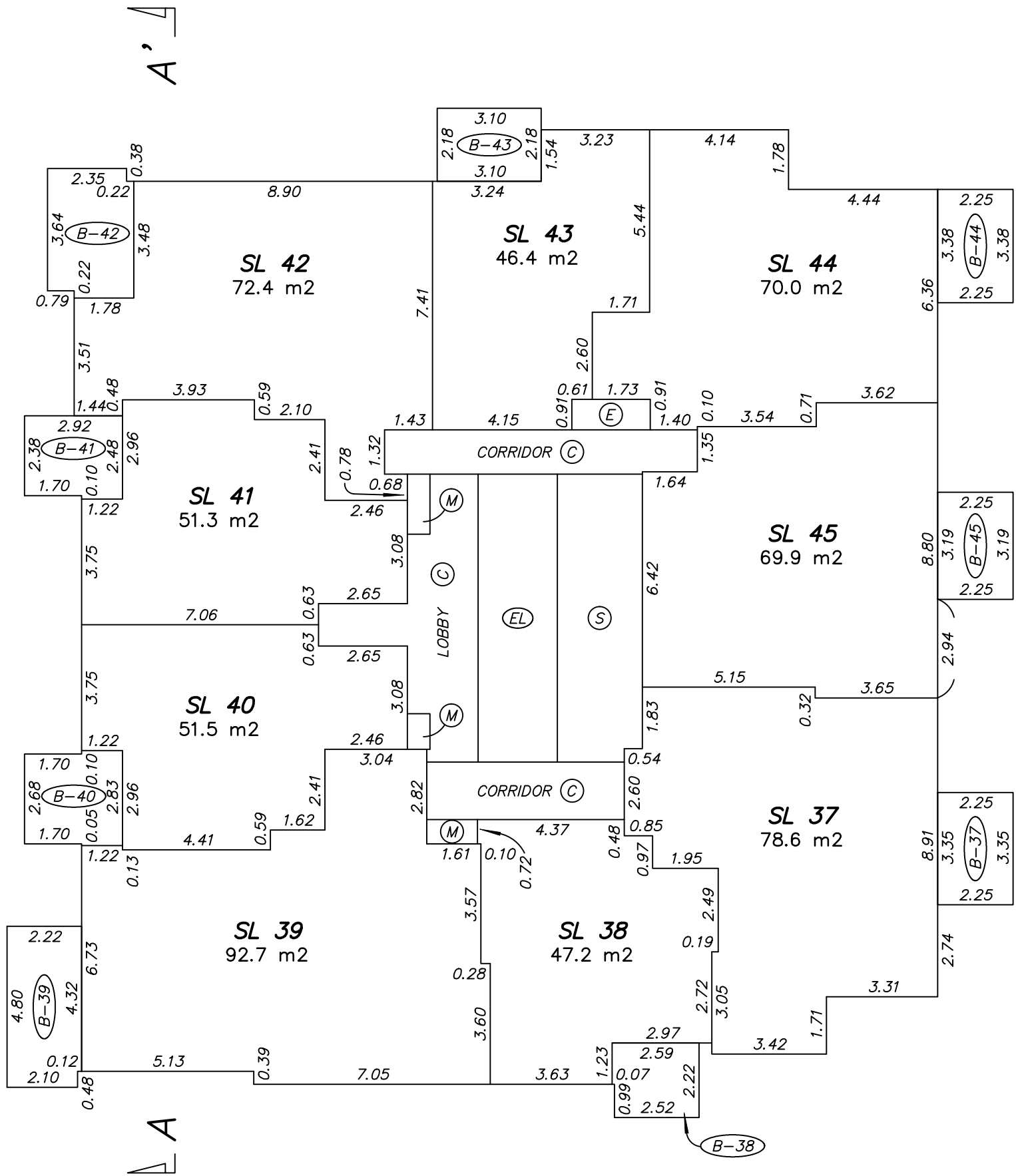
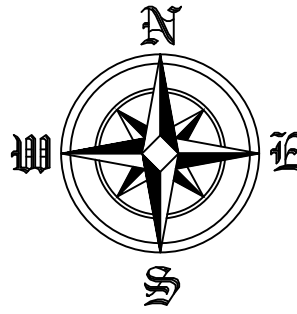

LEVEL 8

STRATA PLAN EPS4147

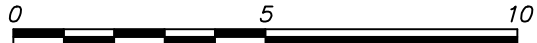

SCALE 1:150 DISTANCES ARE IN METRES

THE INTENDED PLOT SCALE OF THIS PLAN IS 280 mm IN WIDTH BY 432 mm IN HEIGHT (B SIZE) WHEN PLOTTED AT A SCALE OF 1:150.

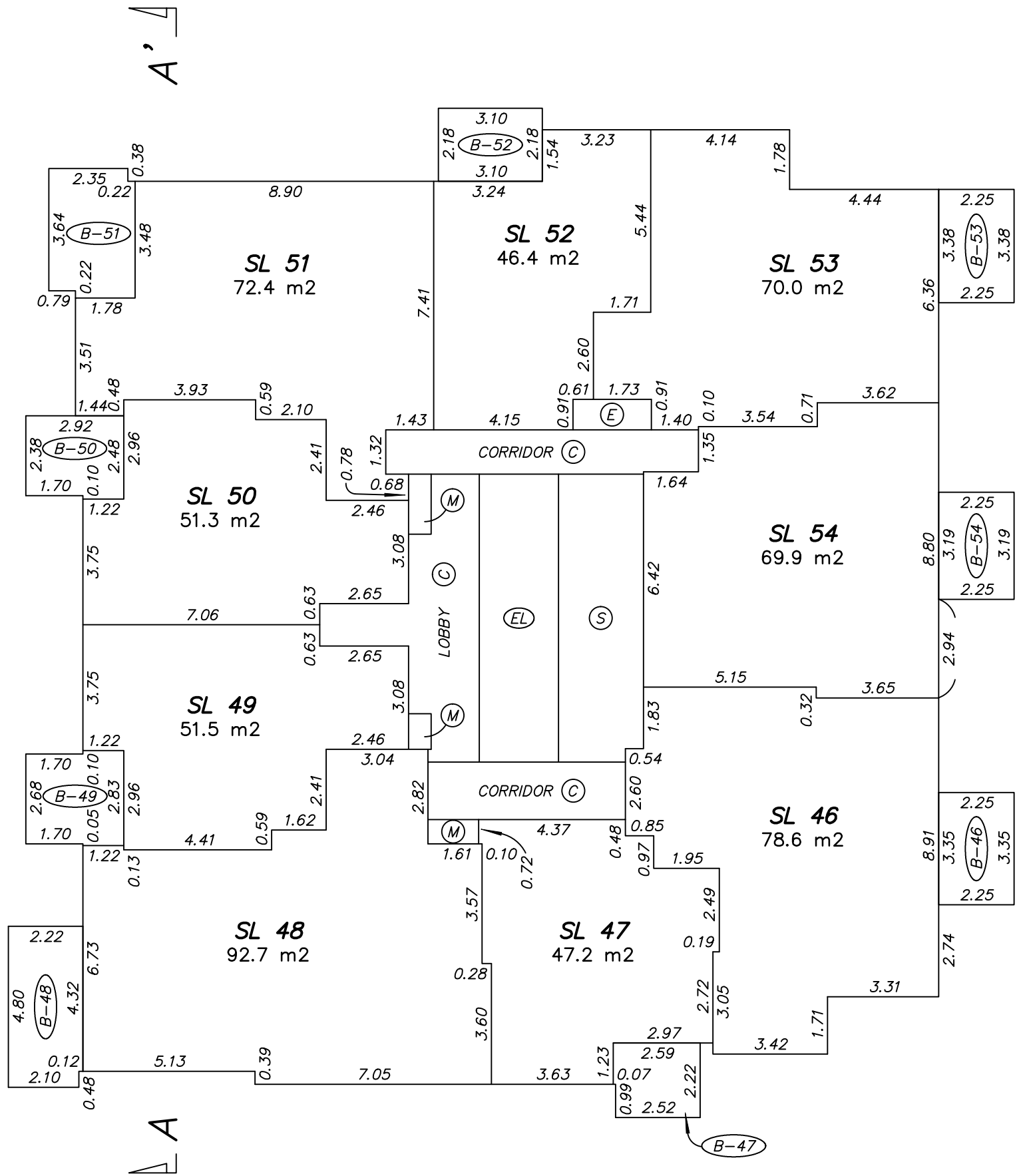
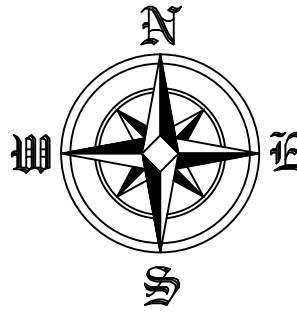

LEVEL 9

STRATA PLAN EPS4147

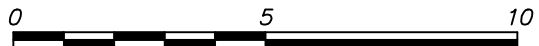

SCALE 1:150 DISTANCES ARE IN METRES

THE INTENDED PLOT SCALE OF THIS PLAN IS 280 mm IN WIDTH BY 432 mm IN HEIGHT (B SIZE) WHEN PLOTTED AT A SCALE OF 1:150.

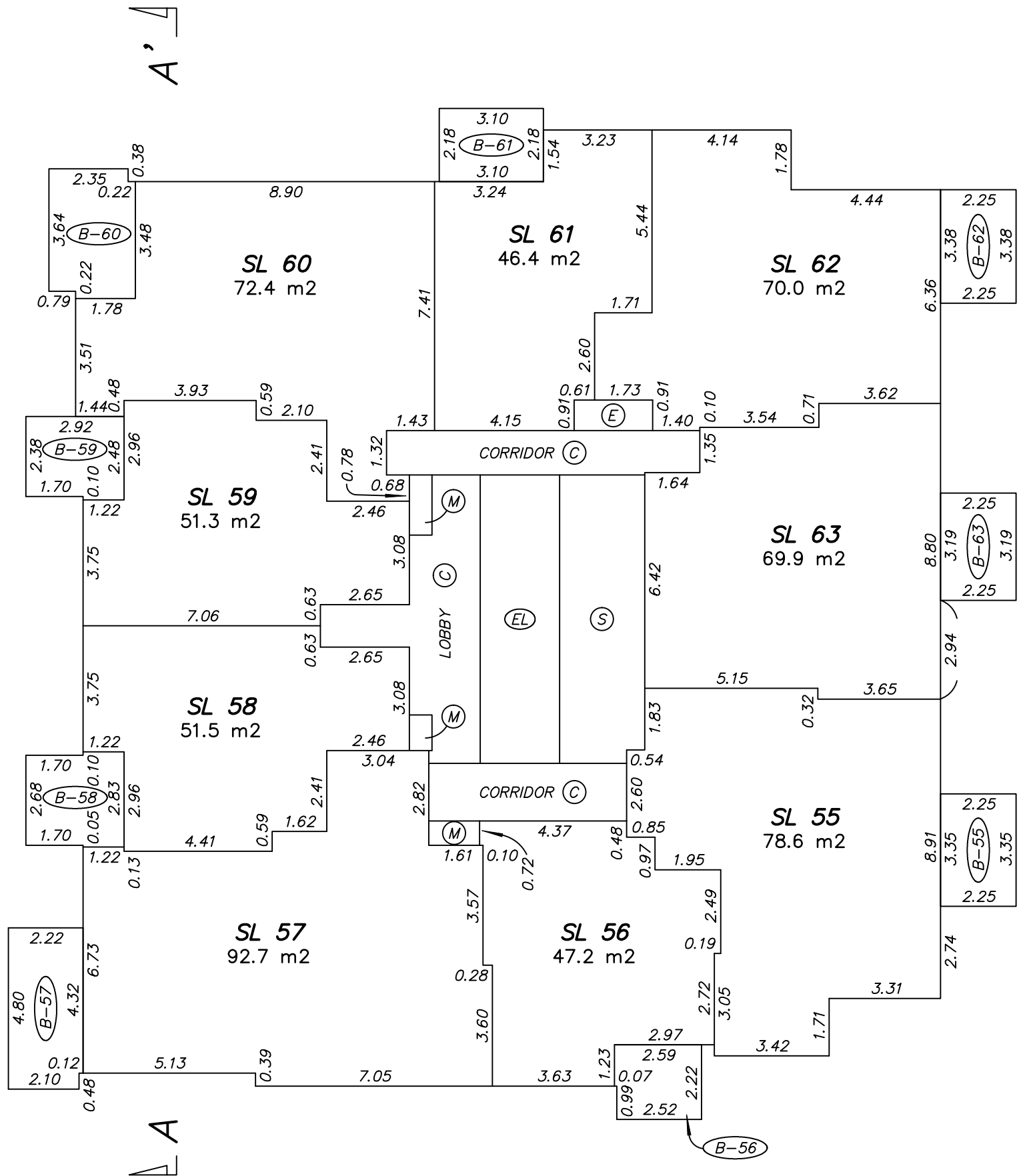
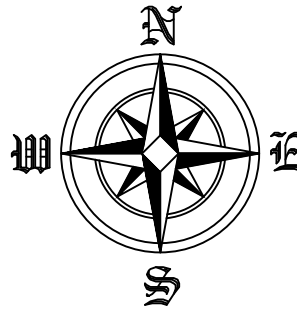

LEVEL 10

STRATA PLAN EPS4147

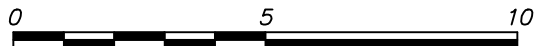

SCALE 1:150 DISTANCES ARE IN METRES

THE INTENDED PLOT SCALE OF THIS PLAN IS 280 mm IN WIDTH BY 432 mm IN HEIGHT (B SIZE) WHEN PLOTTED AT A SCALE OF 1:150.

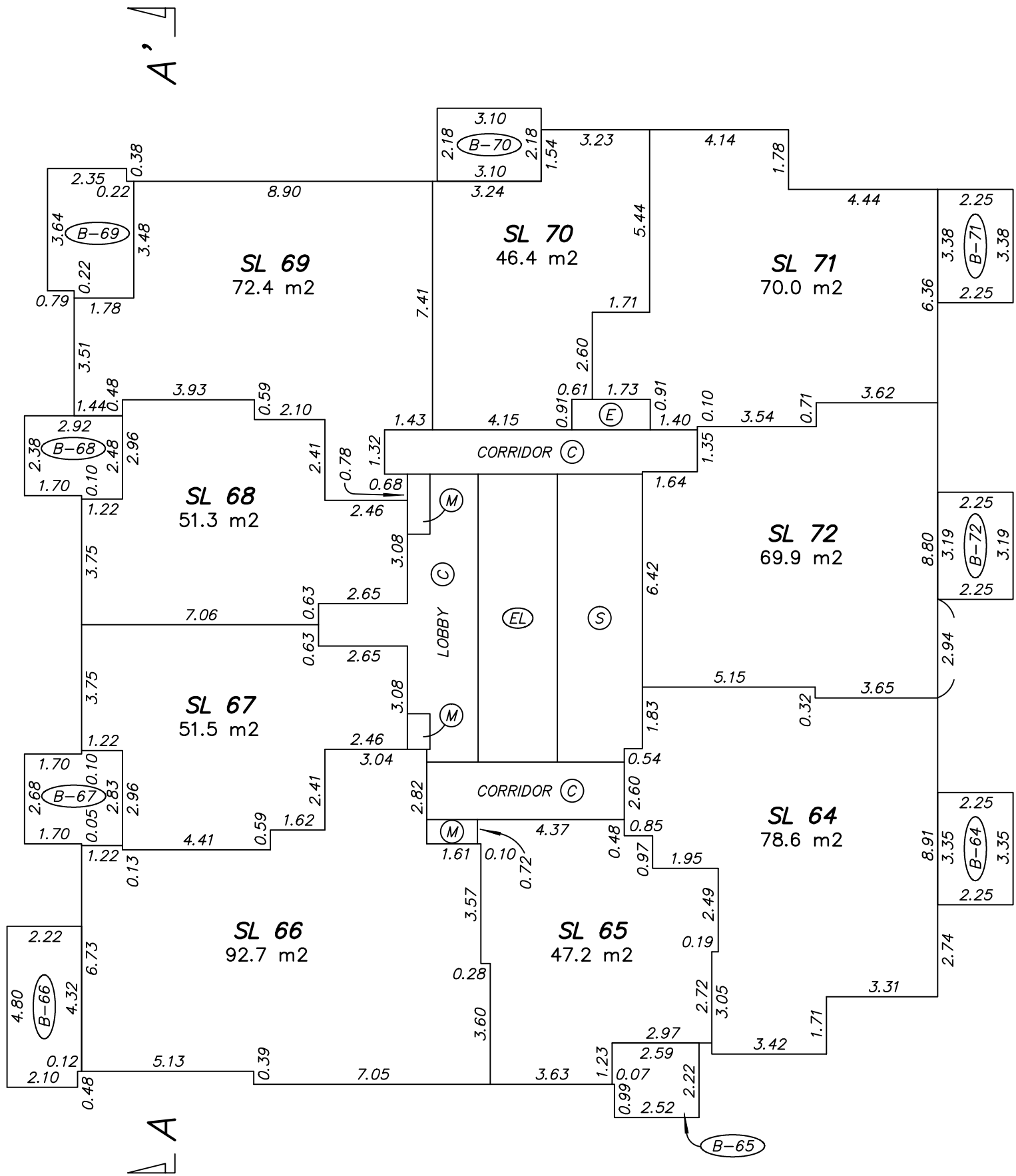
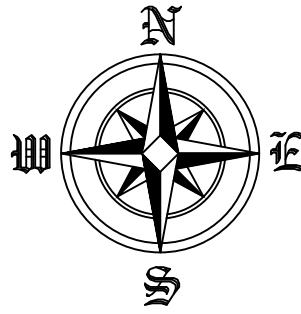

LEVEL 11

STRATA PLAN EPS4147

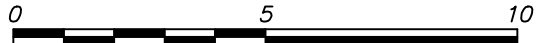

SCALE 1:150 DISTANCES ARE IN METRES

THE INTENDED PLOT SCALE OF THIS PLAN IS 280 mm IN WIDTH BY 432 mm IN HEIGHT (B SIZE) WHEN PLOTTED AT A SCALE OF 1:150.

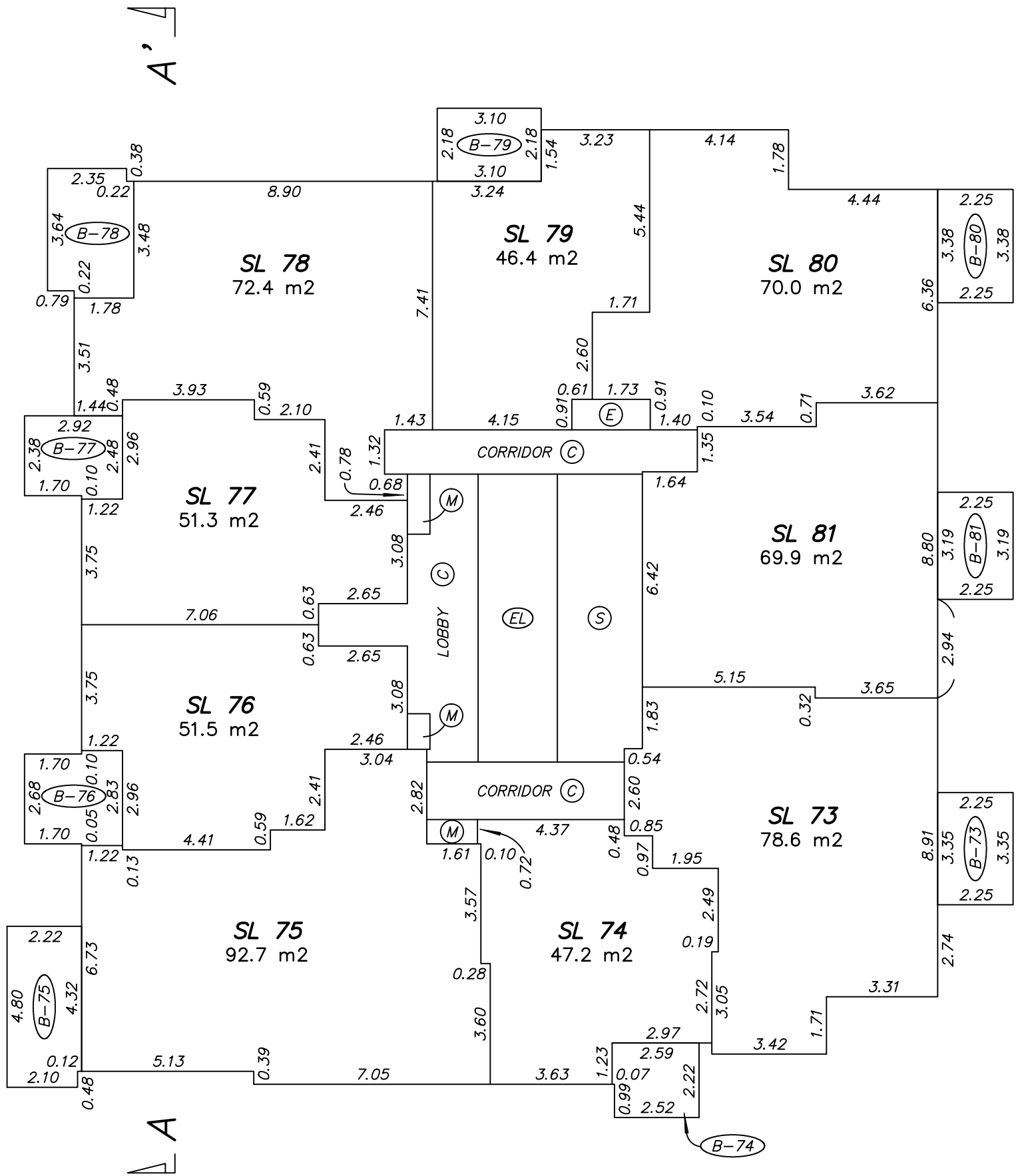
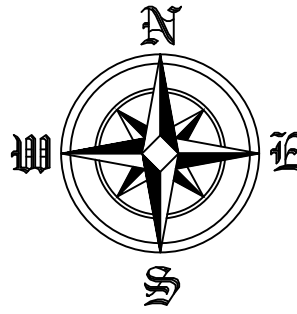

JESSE MORIN, BCLS
Date: JUNE 6, 2017
File: 4413\Strata\Final
Dwg: 4413-FS-Rev.1

LEVEL 12

STRATA PLAN EPS4147

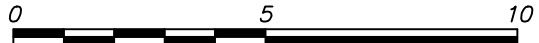

SCALE 1:150 DISTANCES ARE IN METRES

THE INTENDED PLOT SCALE OF THIS PLAN IS 280 mm IN WIDTH BY 432 mm IN HEIGHT (B SIZE) WHEN PLOTTED AT A SCALE OF 1:150.

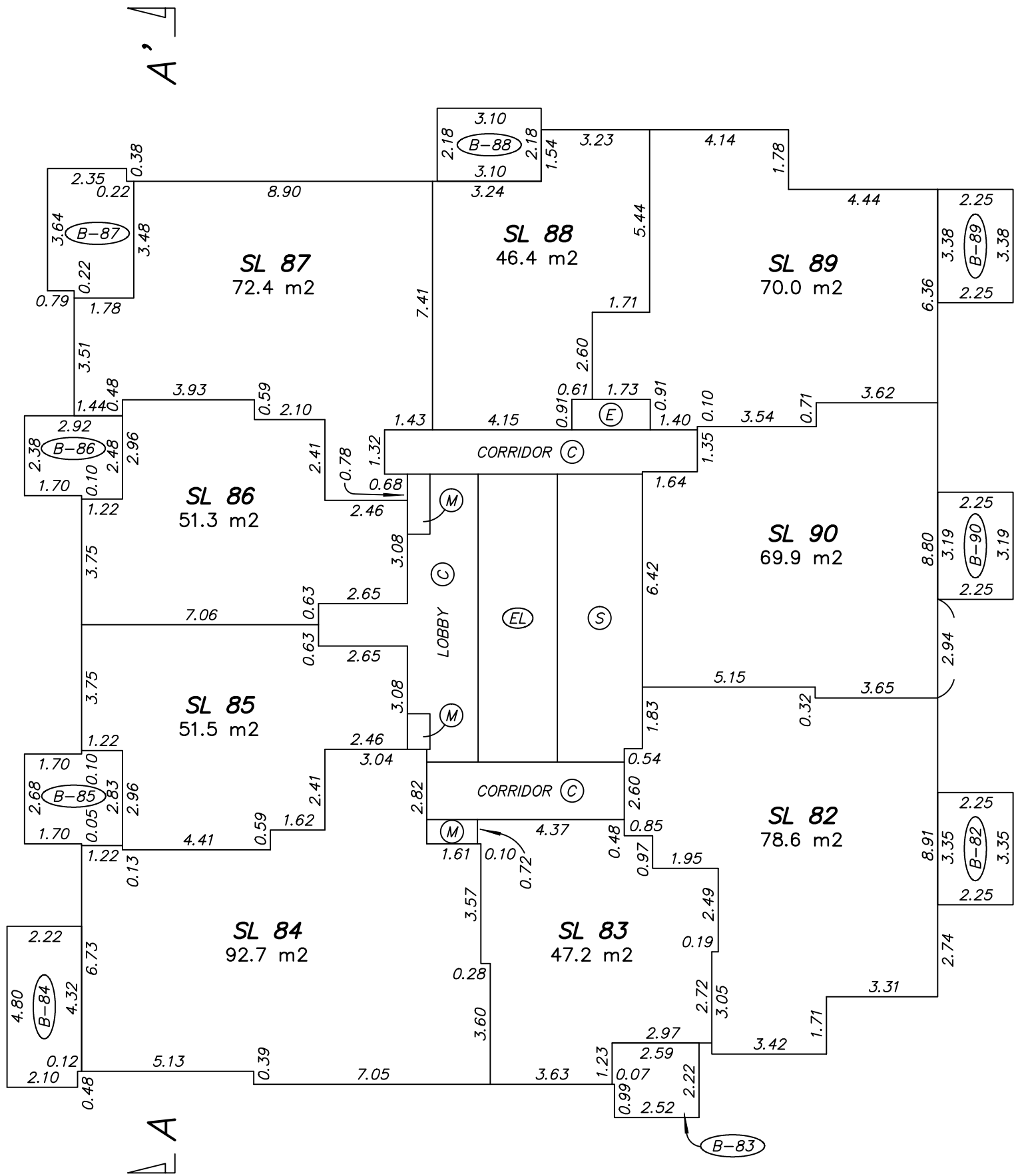
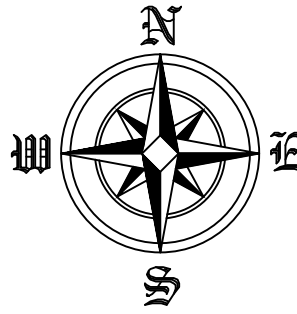

LEVEL 15

STRATA PLAN EPS4147

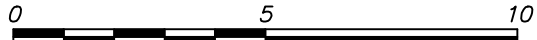

SCALE 1:150 DISTANCES ARE IN METRES

THE INTENDED PLOT SCALE OF THIS PLAN IS 280 mm IN WIDTH BY 432 mm IN HEIGHT (B SIZE) WHEN PLOTTED AT A SCALE OF 1:150.

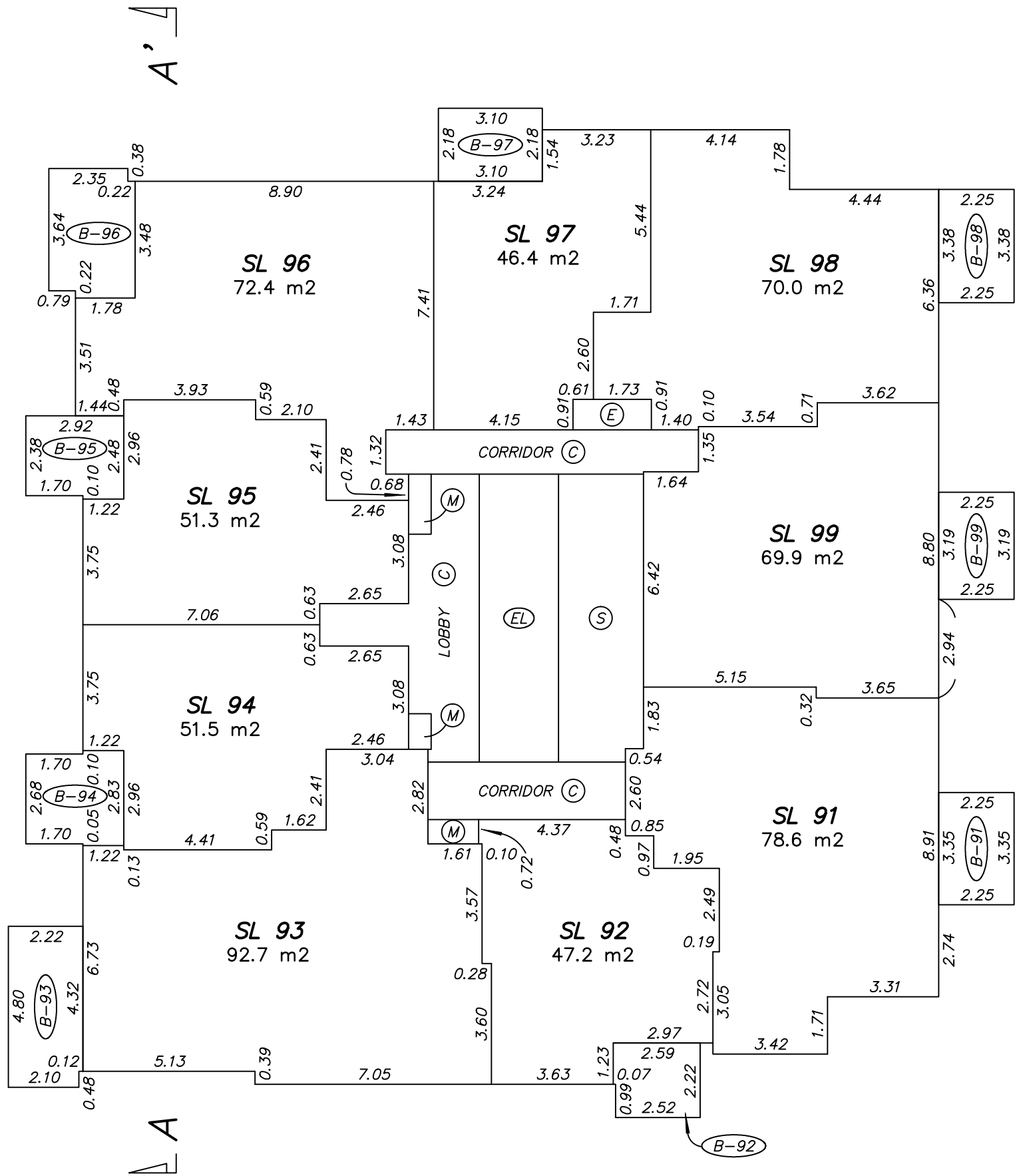
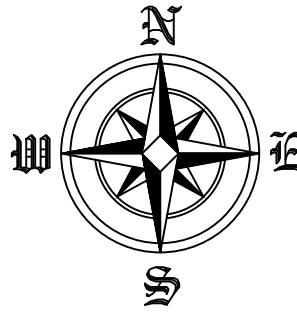

NOTE: THE 13 AND 14th FLOORS HAVE BEEN ELIMINATED FROM CONSECUTIVE FLOOR NUMBERING



JESSE MORIN, BCLS
Date: JUNE 6, 2017
File: 4413\Strata\Final
Dwg: 4413-FS-Rev.1

LEVEL 16

STRATA PLAN EPS4147

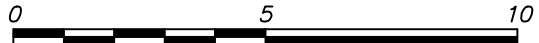

SCALE 1:150 DISTANCES ARE IN METRES

THE INTENDED PLOT SCALE OF THIS PLAN IS 280 mm IN WIDTH BY 432 mm IN HEIGHT (B SIZE) WHEN PLOTTED AT A SCALE OF 1:150.

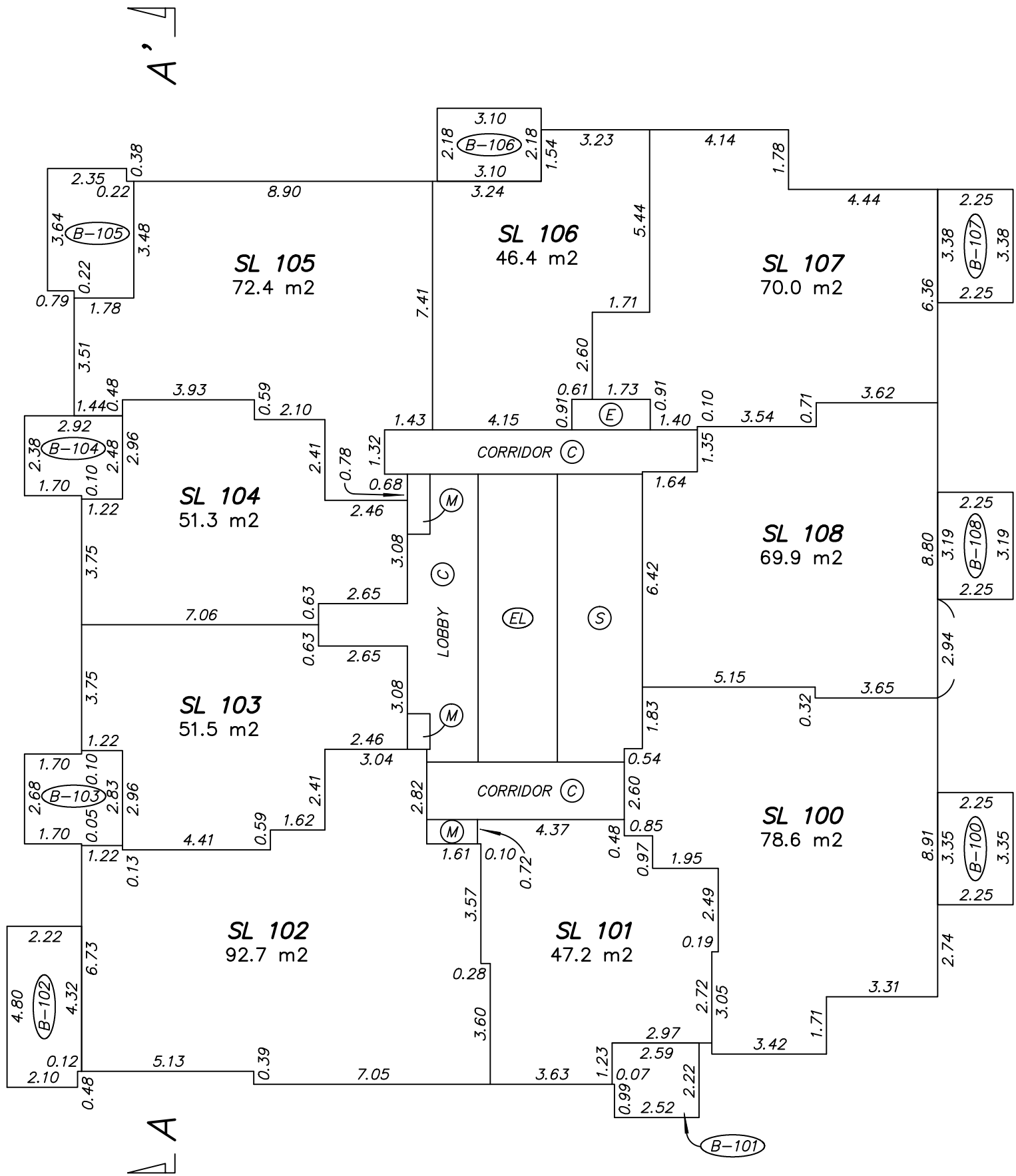
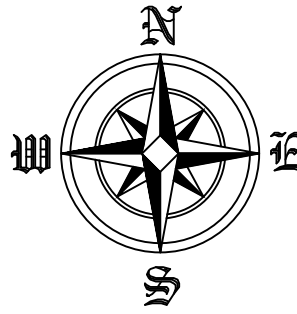

LEVEL 17

STRATA PLAN EPS4147

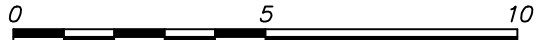

SCALE 1:150 DISTANCES ARE IN METRES

THE INTENDED PLOT SCALE OF THIS PLAN IS 280 mm IN WIDTH BY 432 mm IN HEIGHT (B SIZE) WHEN PLOTTED AT A SCALE OF 1:150.

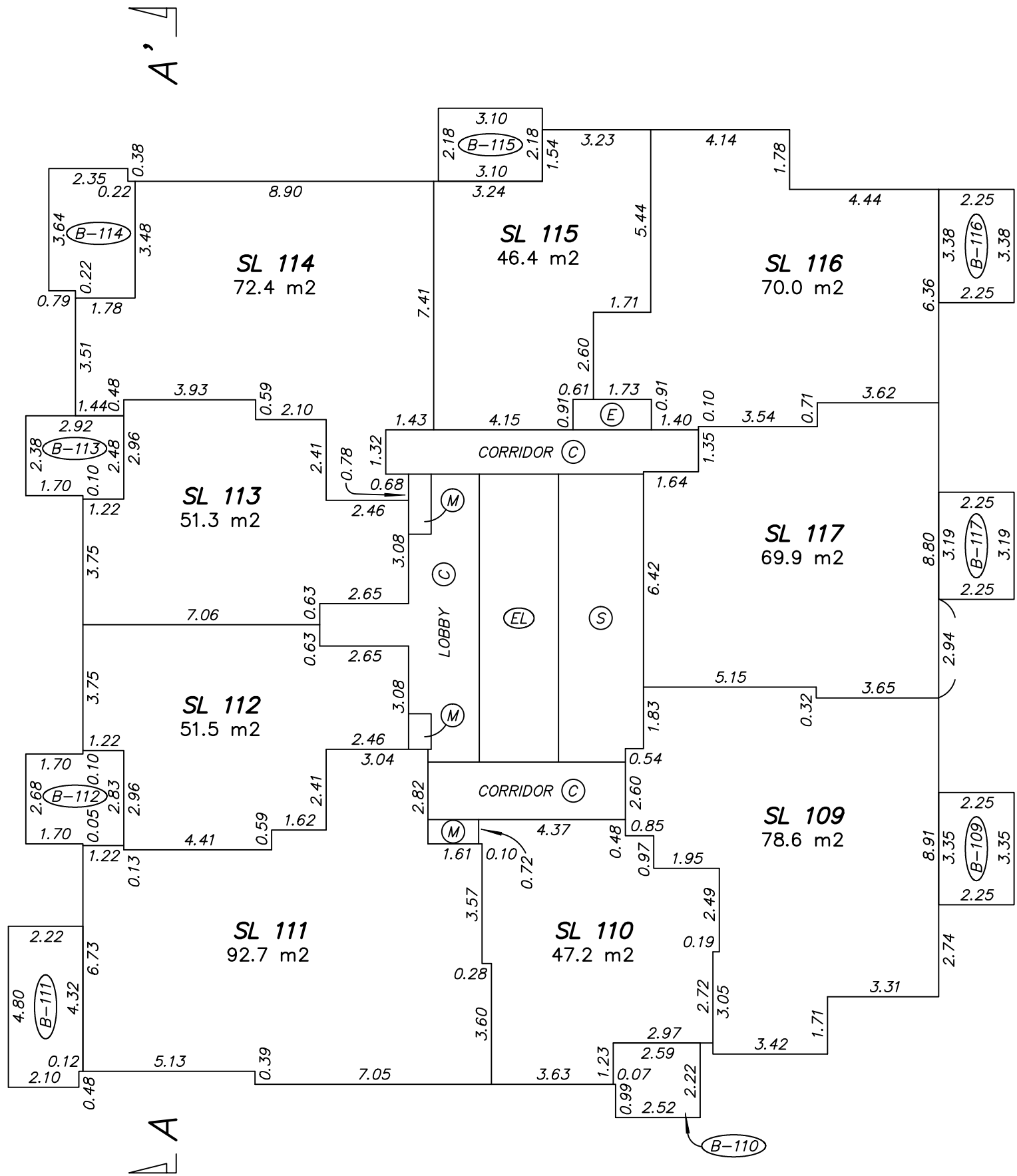
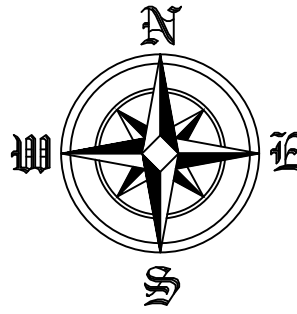

LEVEL 18

STRATA PLAN EPS4147

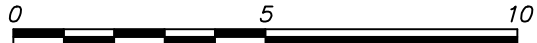

SCALE 1:150 DISTANCES ARE IN METRES

THE INTENDED PLOT SCALE OF THIS PLAN IS 280 mm IN WIDTH BY 432 mm IN HEIGHT (B SIZE) WHEN PLOTTED AT A SCALE OF 1:150.

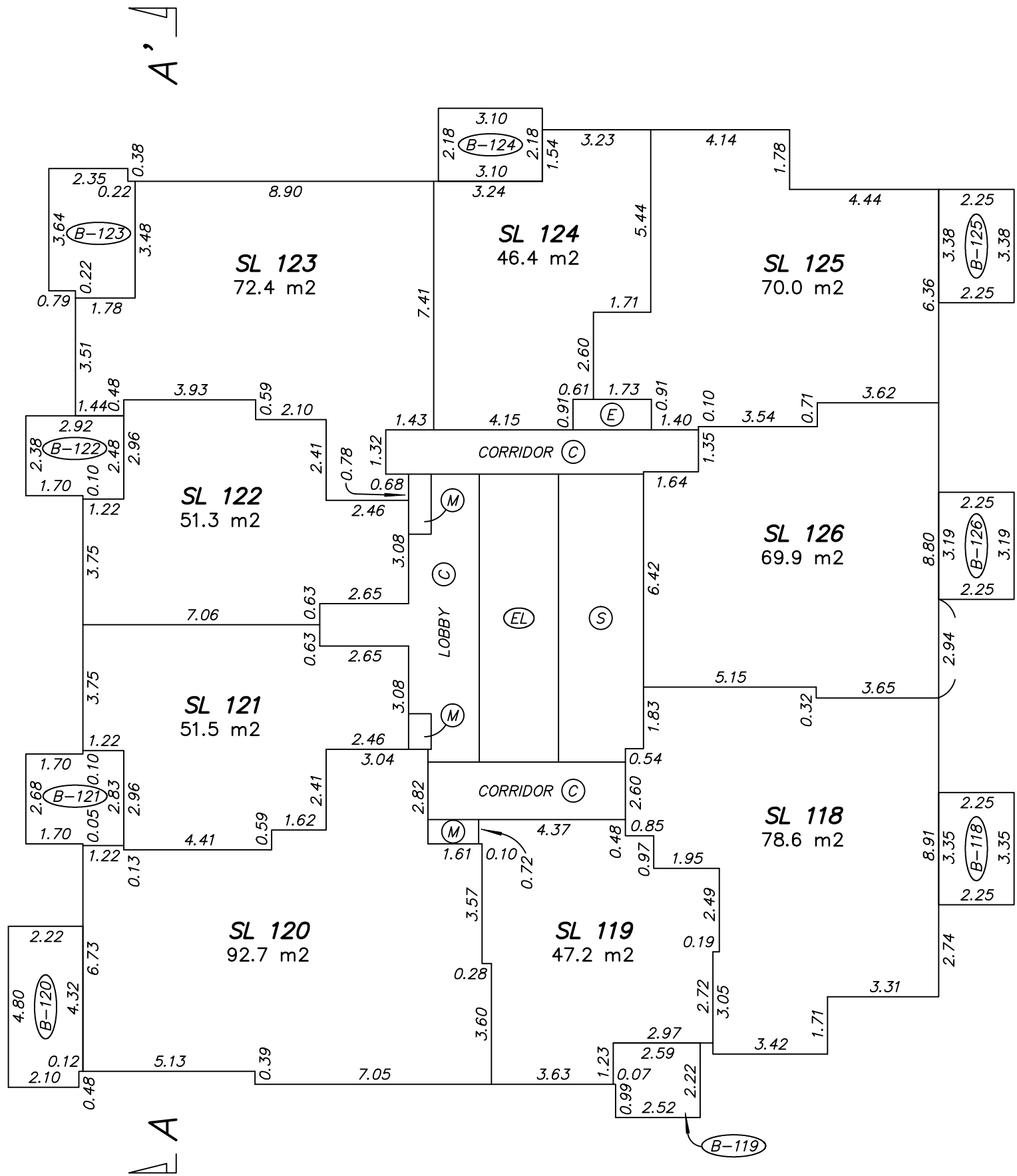
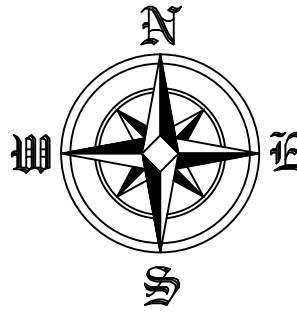

LEVEL 19

STRATA PLAN EPS4147

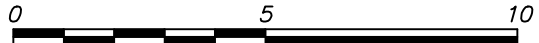

SCALE 1:150 DISTANCES ARE IN METRES

THE INTENDED PLOT SCALE OF THIS PLAN IS 280 mm IN WIDTH BY 432 mm IN HEIGHT (B SIZE) WHEN PLOTTED AT A SCALE OF 1:150.

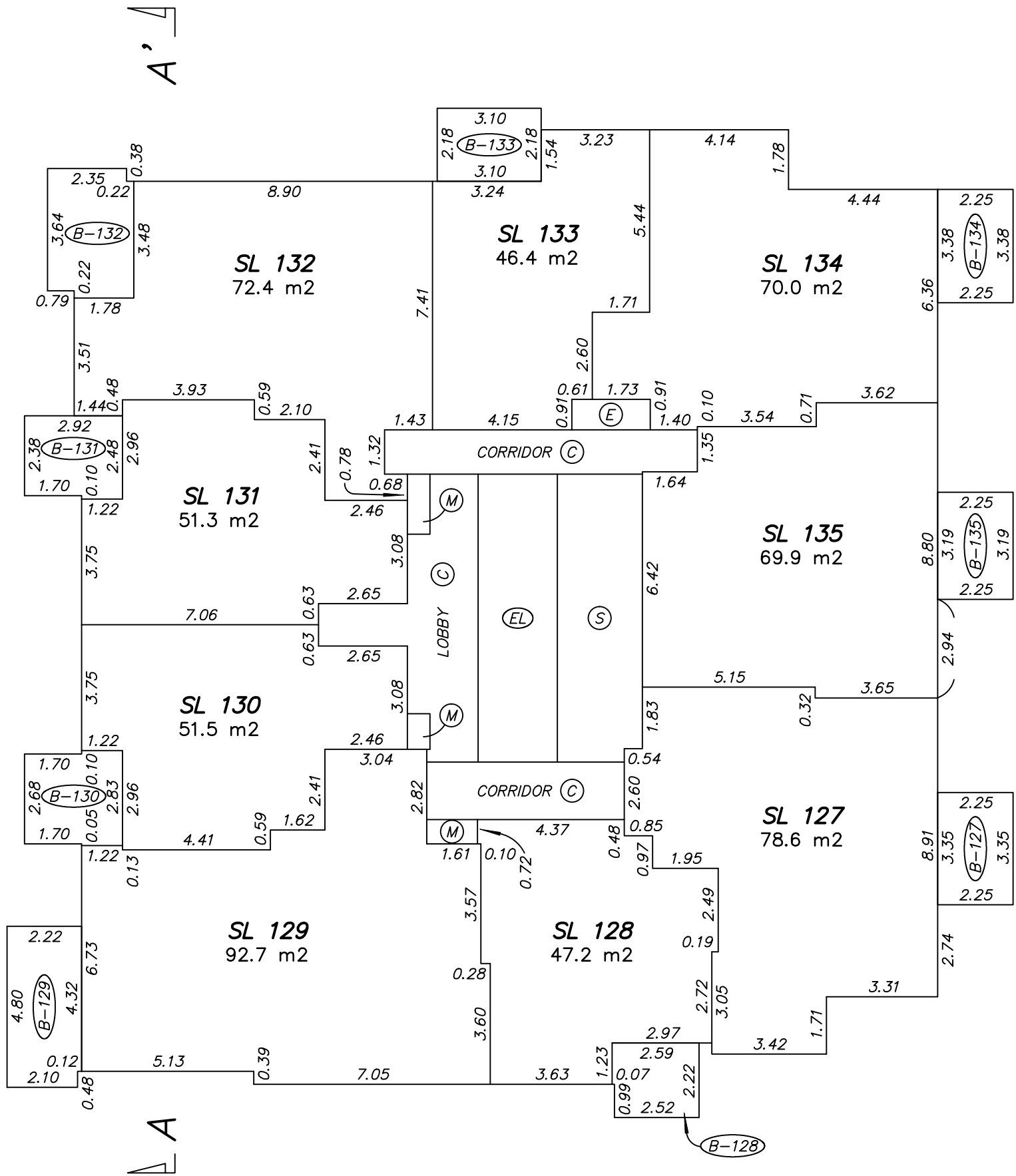
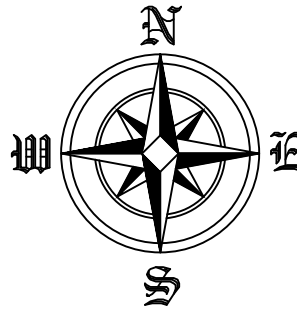

LEVEL 20

STRATA PLAN EPS4147

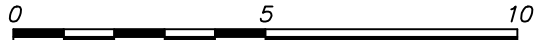

SCALE 1:150 DISTANCES ARE IN METRES

THE INTENDED PLOT SCALE OF THIS PLAN IS 280 mm IN WIDTH BY 432 mm IN HEIGHT (B SIZE) WHEN PLOTTED AT A SCALE OF 1:150.

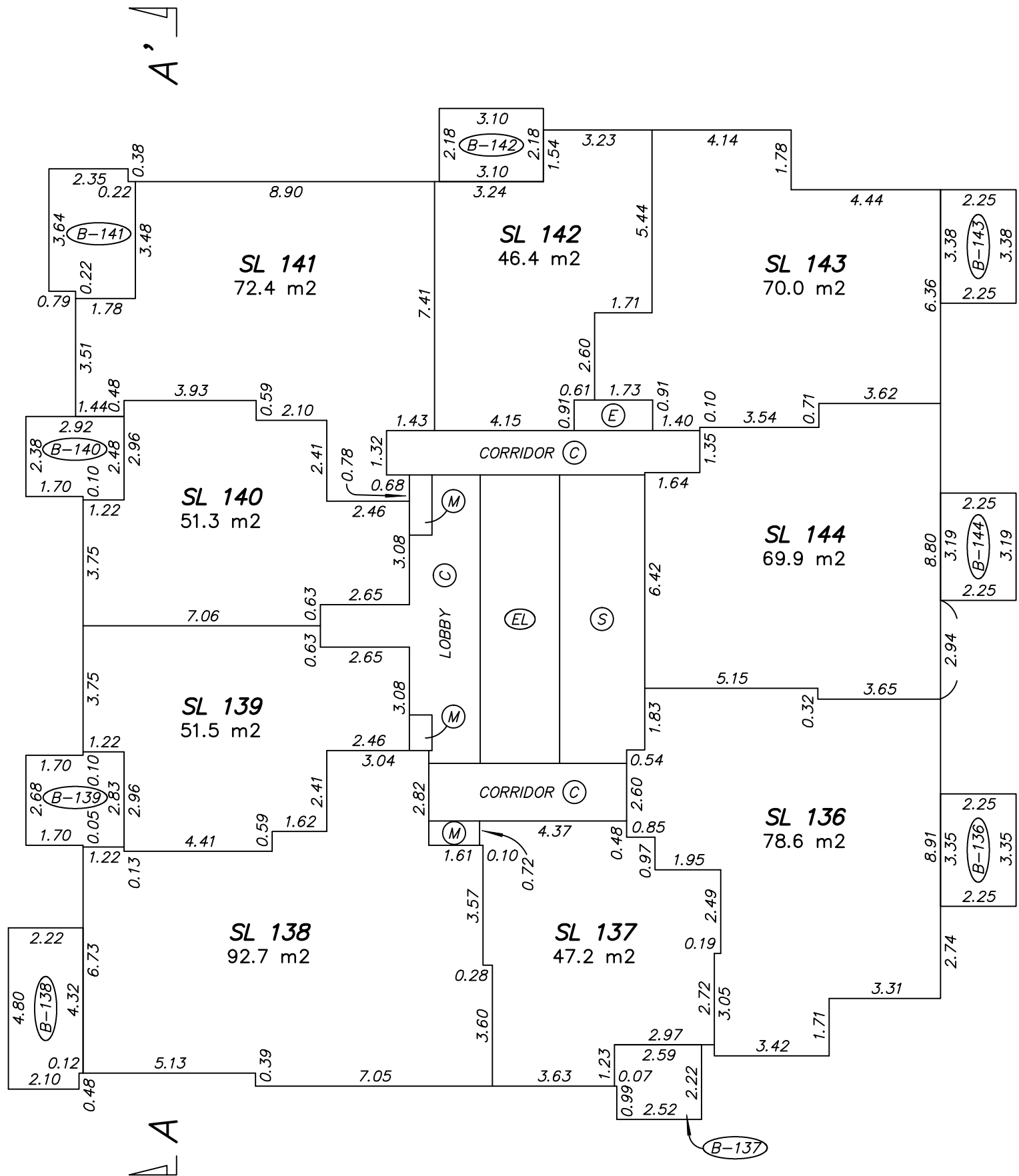
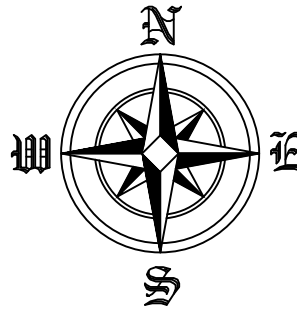

LEVEL 21

STRATA PLAN EPS4147

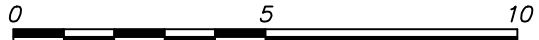

SCALE 1:150 DISTANCES ARE IN METRES

THE INTENDED PLOT SCALE OF THIS PLAN IS 280 mm IN WIDTH BY 432 mm IN HEIGHT (B SIZE) WHEN PLOTTED AT A SCALE OF 1:150.

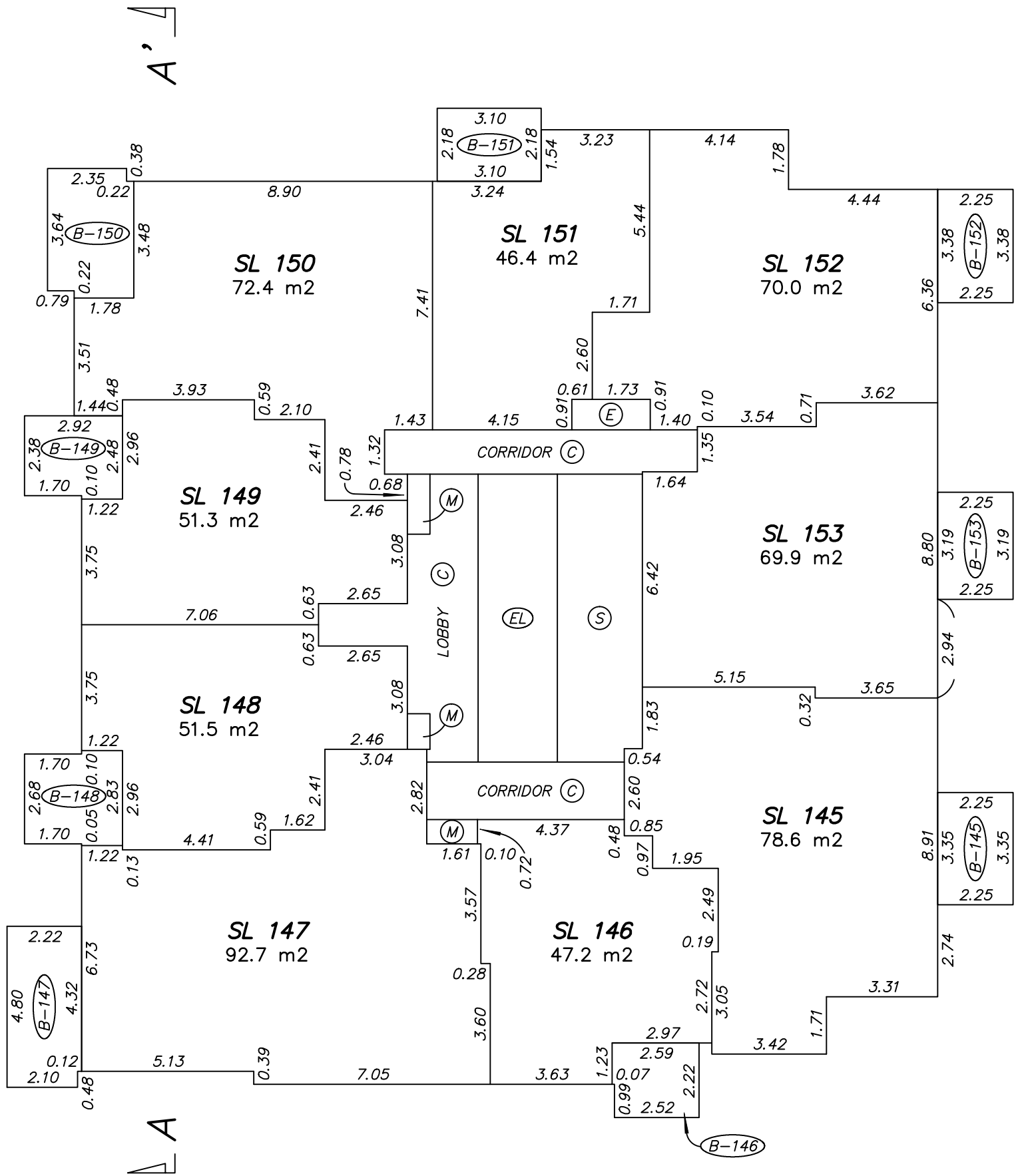
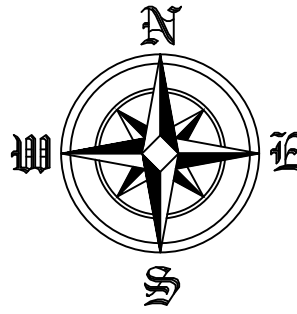

LEVEL 22

STRATA PLAN EPS4147

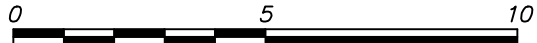

SCALE 1:150 DISTANCES ARE IN METRES

THE INTENDED PLOT SCALE OF THIS PLAN IS 280 mm IN WIDTH BY 432 mm IN HEIGHT (B SIZE) WHEN PLOTTED AT A SCALE OF 1:150.

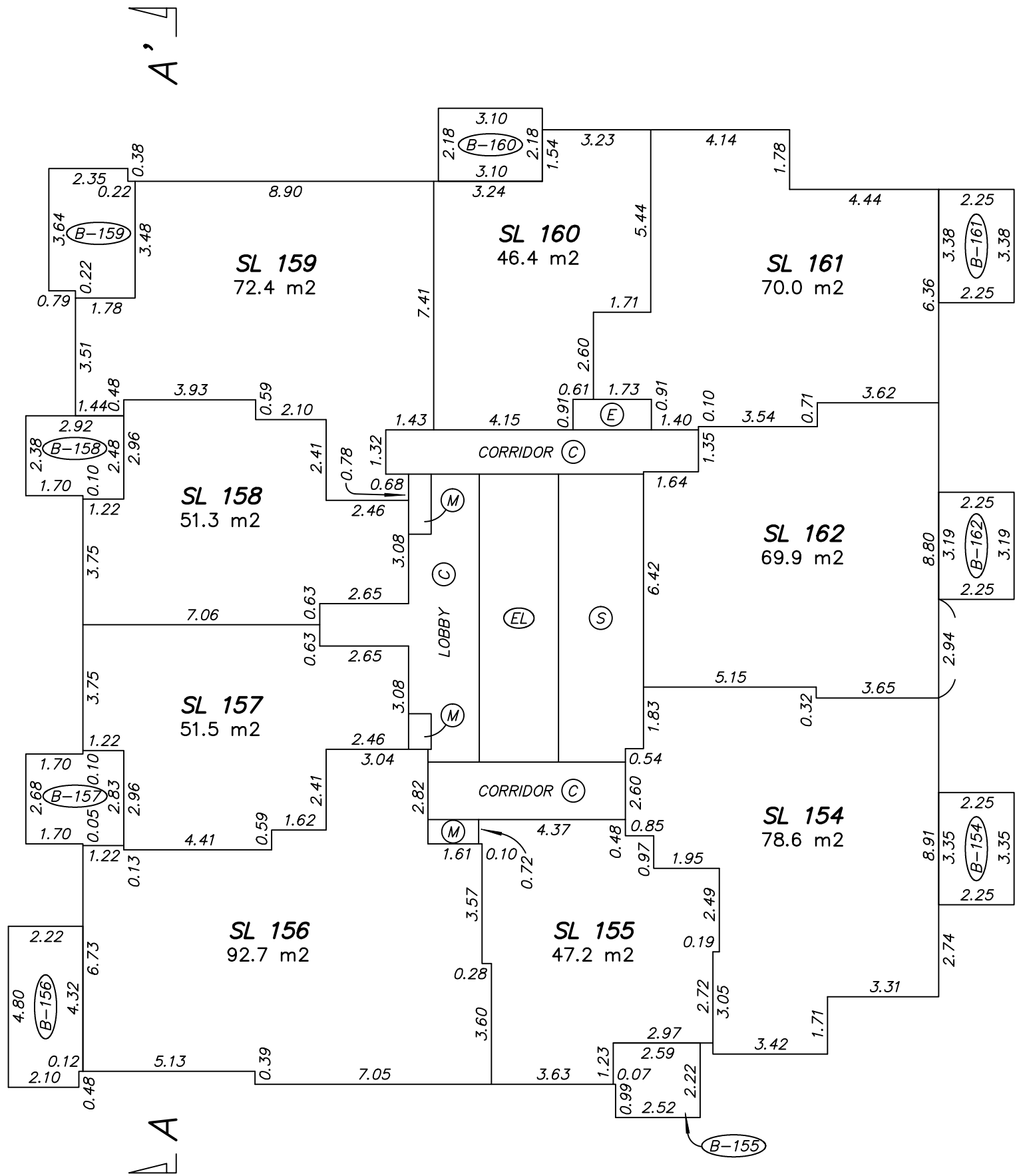
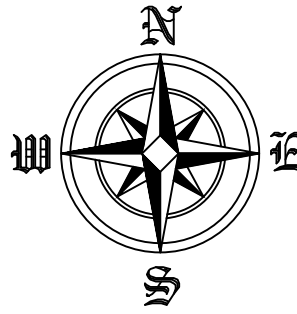

LEVEL 23

STRATA PLAN EPS4147

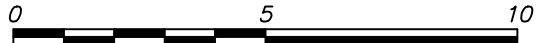

SCALE 1:150 DISTANCES ARE IN METRES

THE INTENDED PLOT SCALE OF THIS PLAN IS 280 mm IN WIDTH BY 432 mm IN HEIGHT (B SIZE) WHEN PLOTTED AT A SCALE OF 1:150.

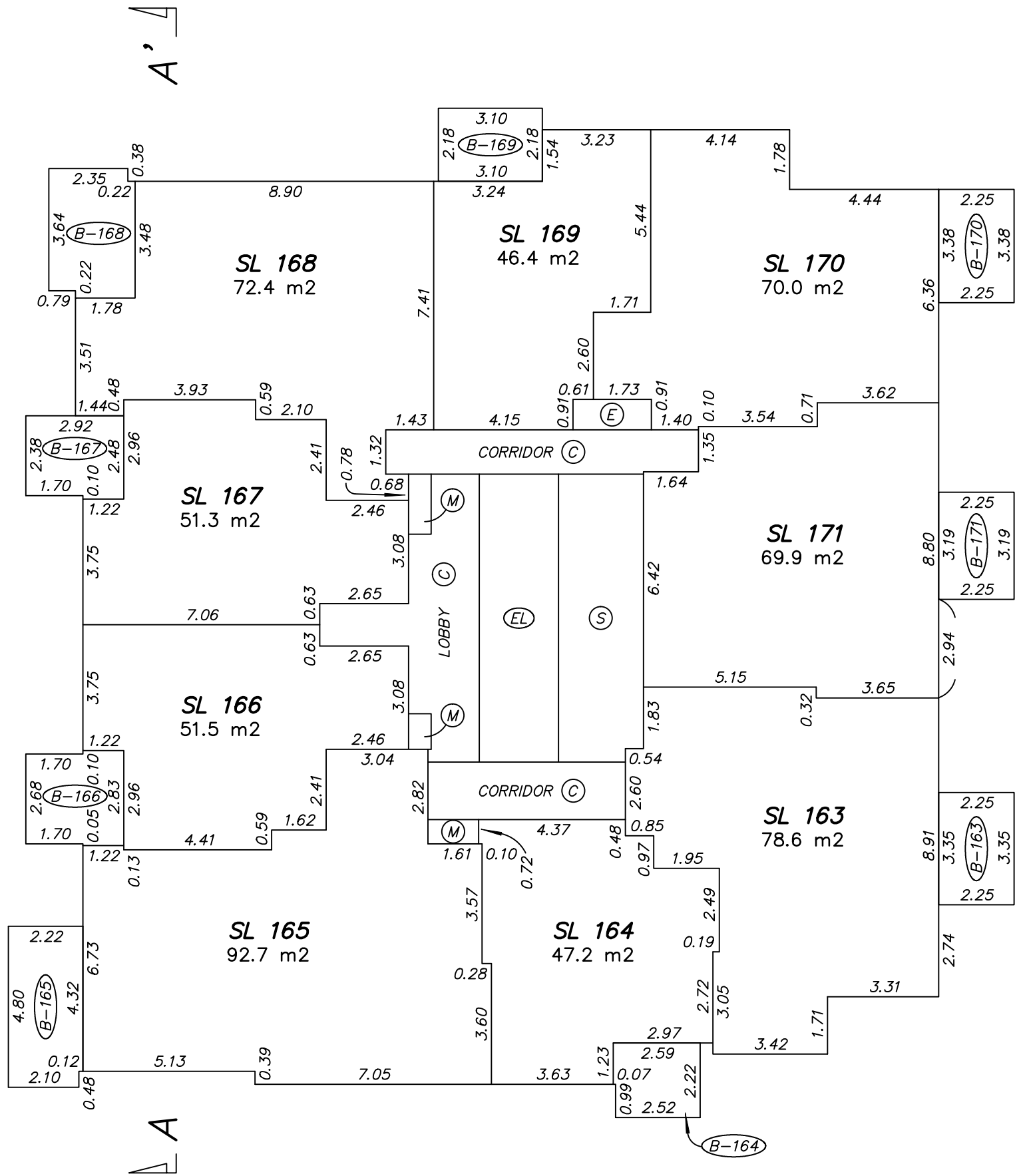
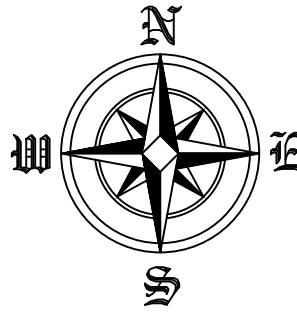

LEVEL 25

STRATA PLAN EPS4147

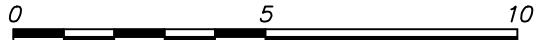

SCALE 1:150 DISTANCES ARE IN METRES

THE INTENDED PLOT SCALE OF THIS PLAN IS 280 mm IN WIDTH BY 432 mm IN HEIGHT (B SIZE) WHEN PLOTTED AT A SCALE OF 1:150.

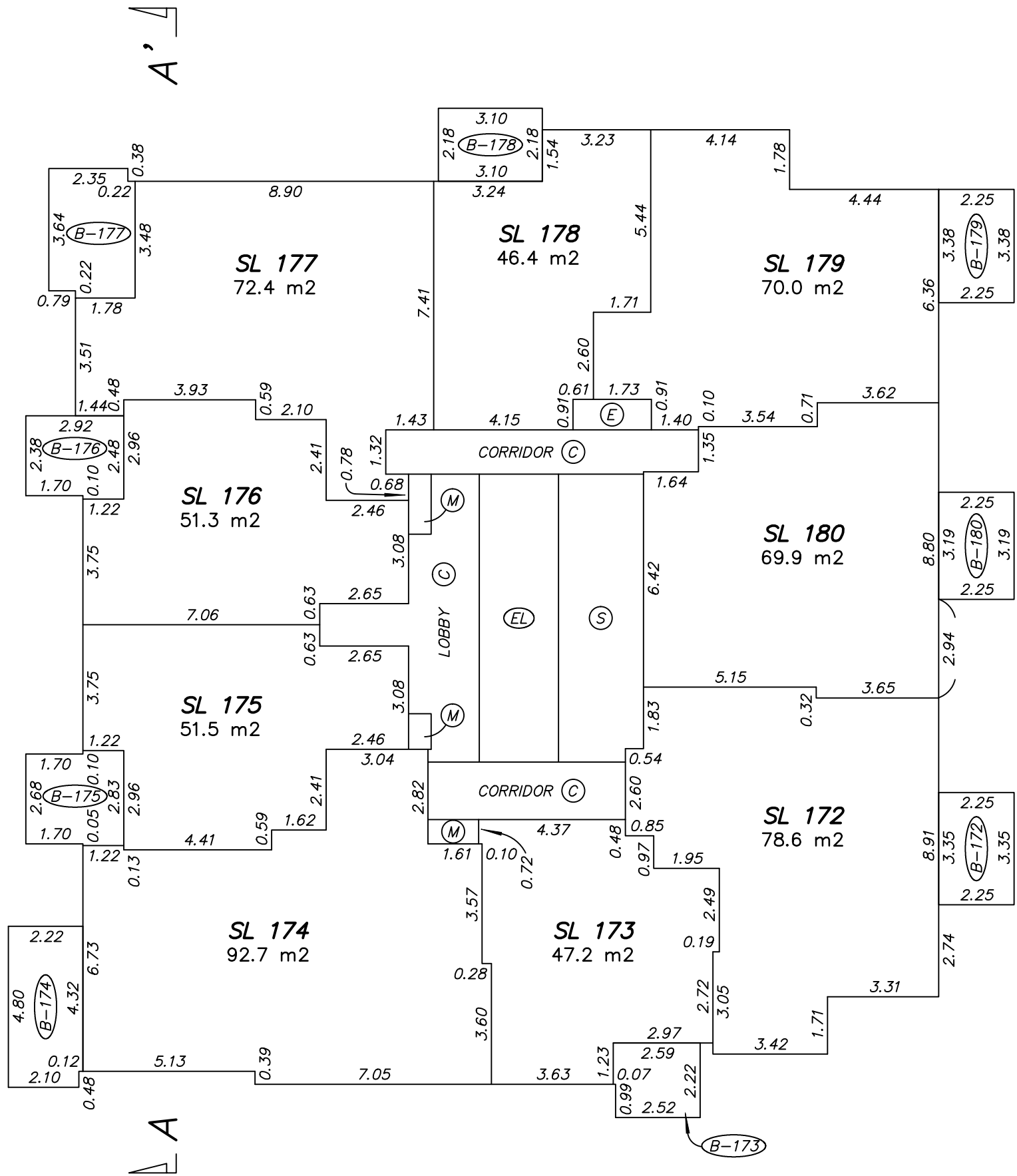
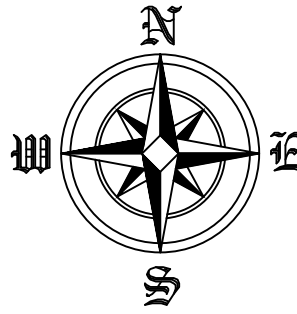

NOTE: THE 24th FLOOR HAS BEEN ELIMINATED FROM CONSECUTIVE FLOOR NUMBERING



JESSE MORIN, BCLS
Date: JUNE 6, 2017
File: 4413\Strata\Final
Dwg: 4413-FS-Rev.1

LEVEL 26

STRATA PLAN EPS4147

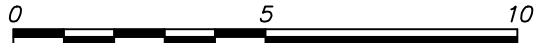

SCALE 1:150 DISTANCES ARE IN METRES

THE INTENDED PLOT SCALE OF THIS PLAN IS 280 mm IN WIDTH BY 432 mm IN HEIGHT (B SIZE) WHEN PLOTTED AT A SCALE OF 1:150.

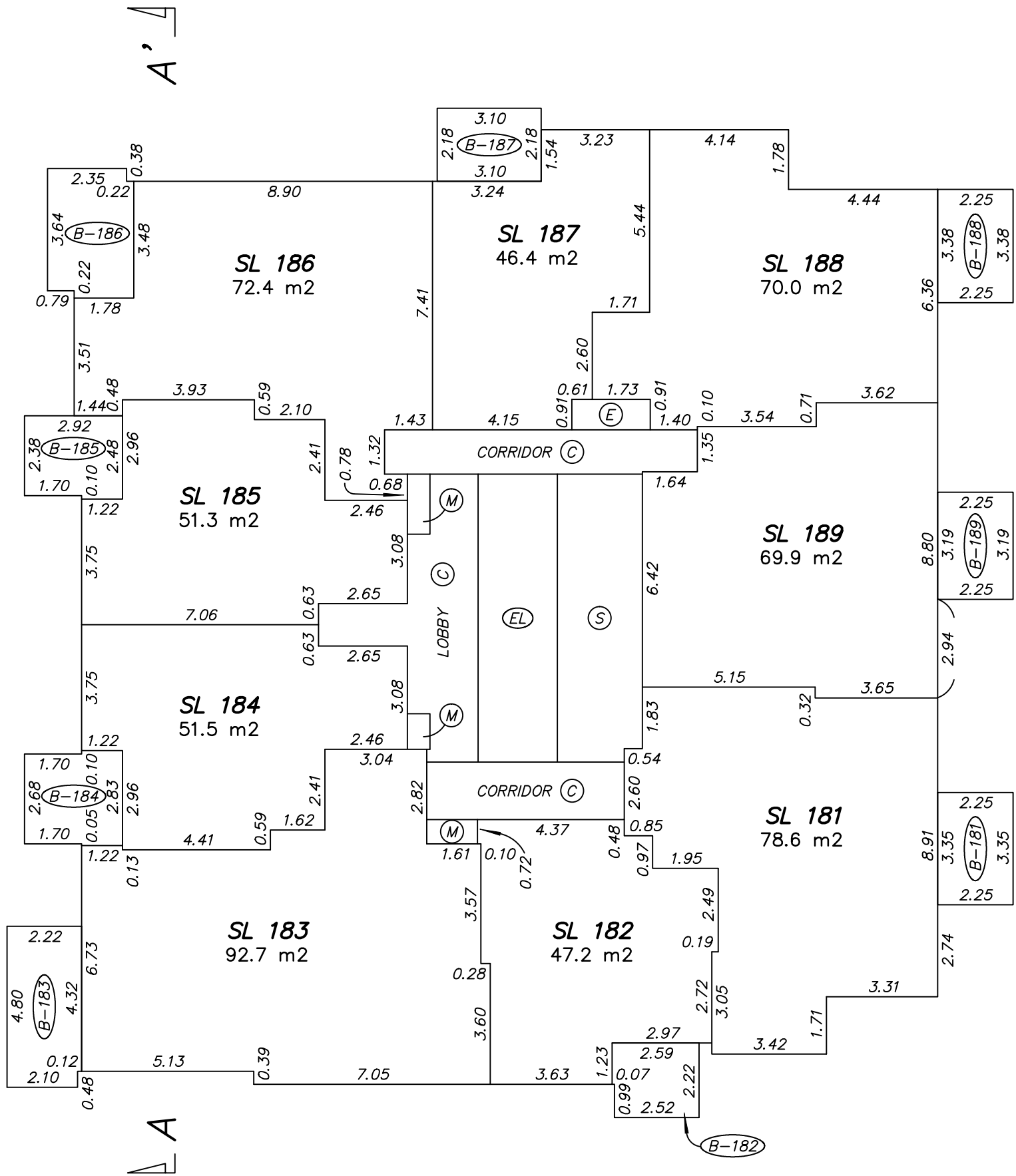
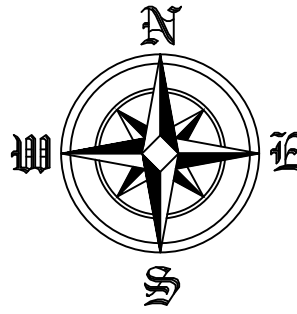

LEVEL 27

STRATA PLAN EPS4147

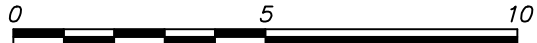

SCALE 1:150 DISTANCES ARE IN METRES

THE INTENDED PLOT SCALE OF THIS PLAN IS 280 mm IN WIDTH BY 432 mm IN HEIGHT (B SIZE) WHEN PLOTTED AT A SCALE OF 1:150.

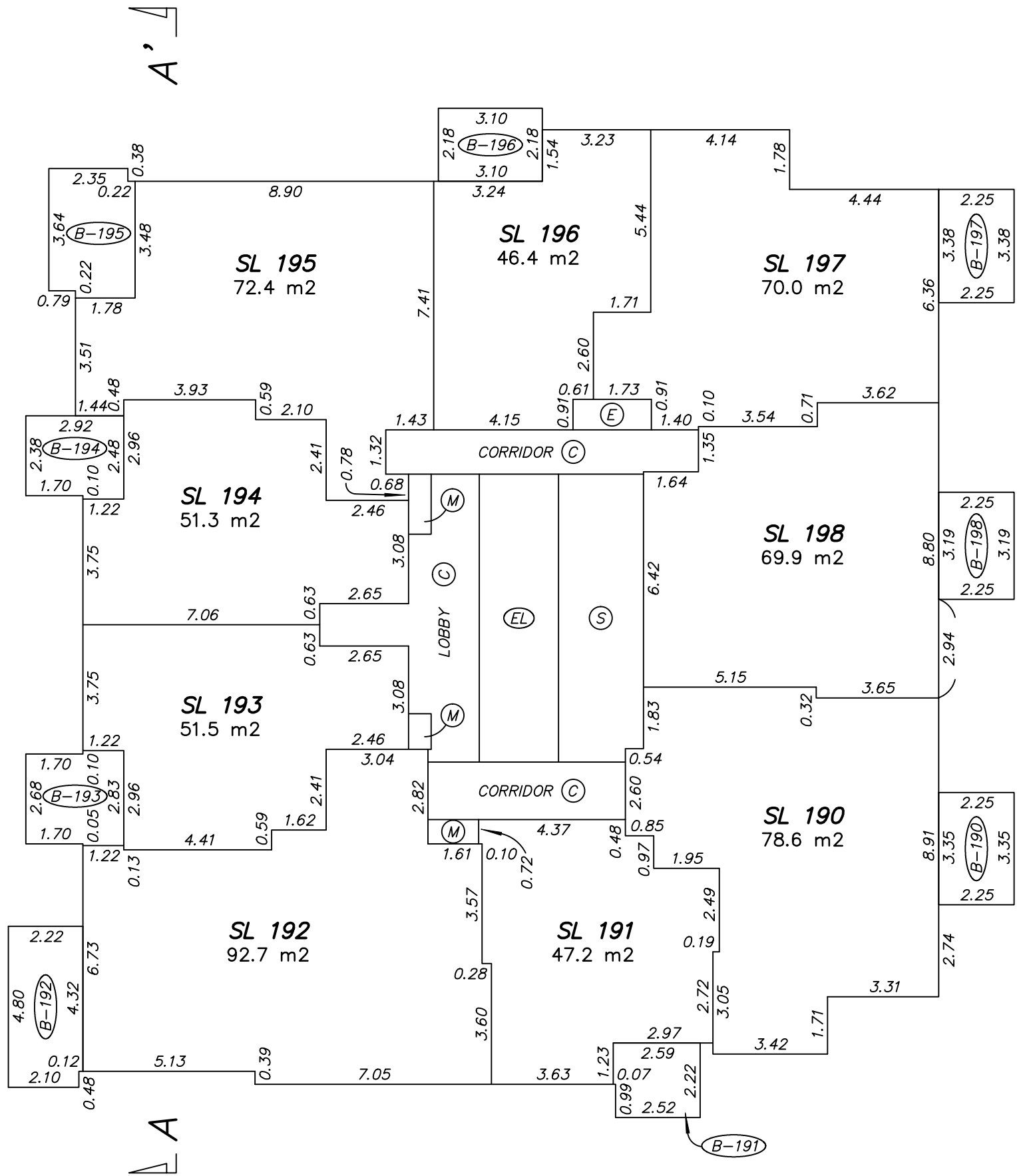
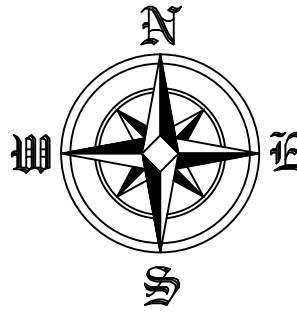

LEVEL 28

STRATA PLAN EPS4147

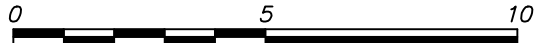

SCALE 1:150 DISTANCES ARE IN METRES

THE INTENDED PLOT SCALE OF THIS PLAN IS 280 mm IN WIDTH BY 432 mm IN HEIGHT (B SIZE) WHEN PLOTTED AT A SCALE OF 1:150.

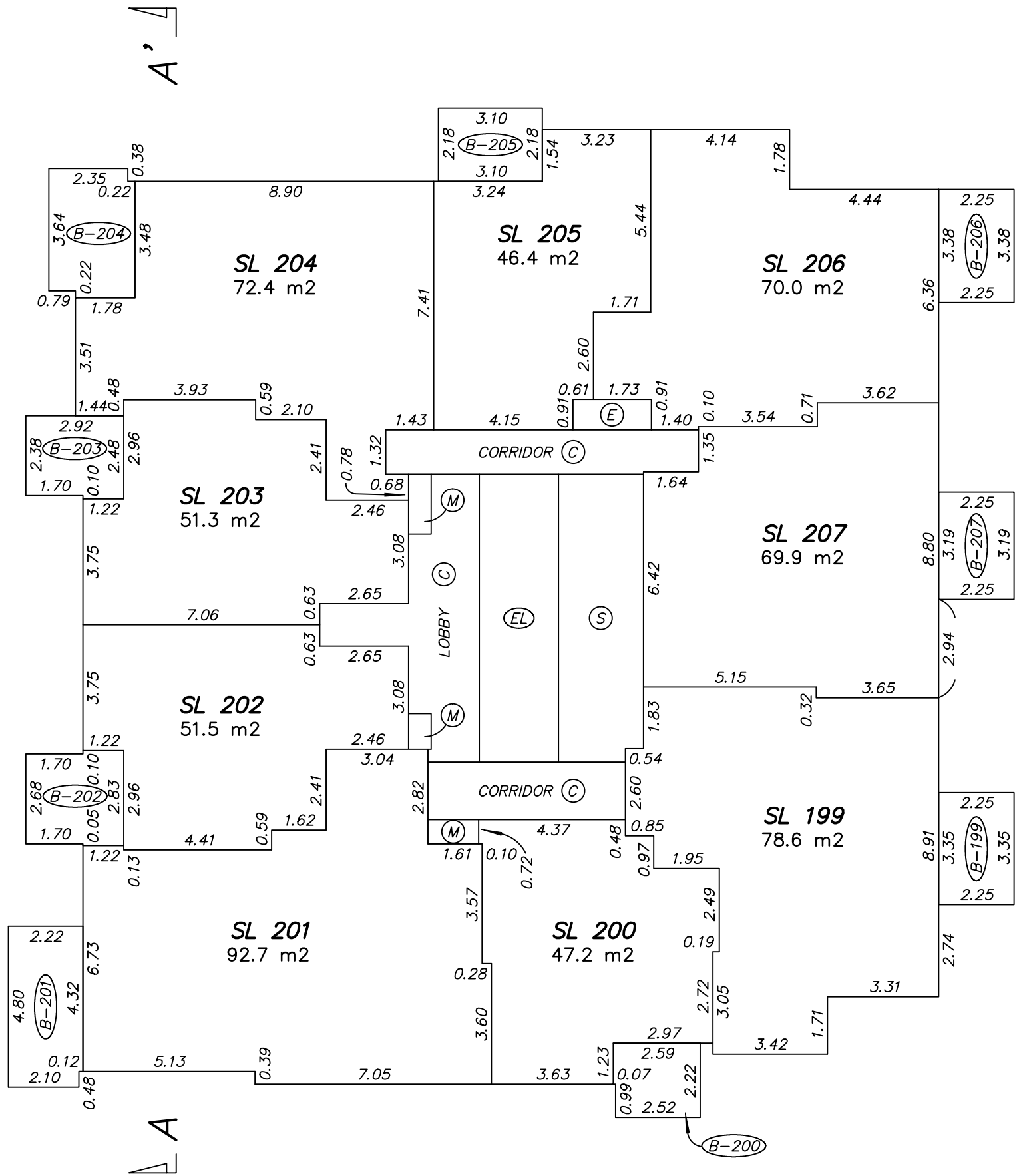
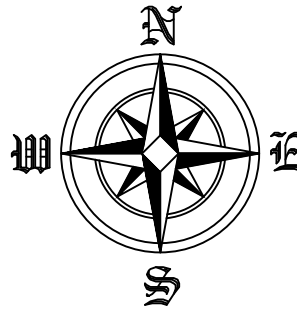

LEVEL 29

STRATA PLAN EPS4147

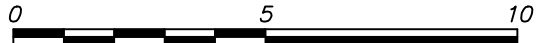

SCALE 1:150 DISTANCES ARE IN METRES

THE INTENDED PLOT SCALE OF THIS PLAN IS 280 mm IN WIDTH BY 432 mm IN HEIGHT (B SIZE) WHEN PLOTTED AT A SCALE OF 1:150.

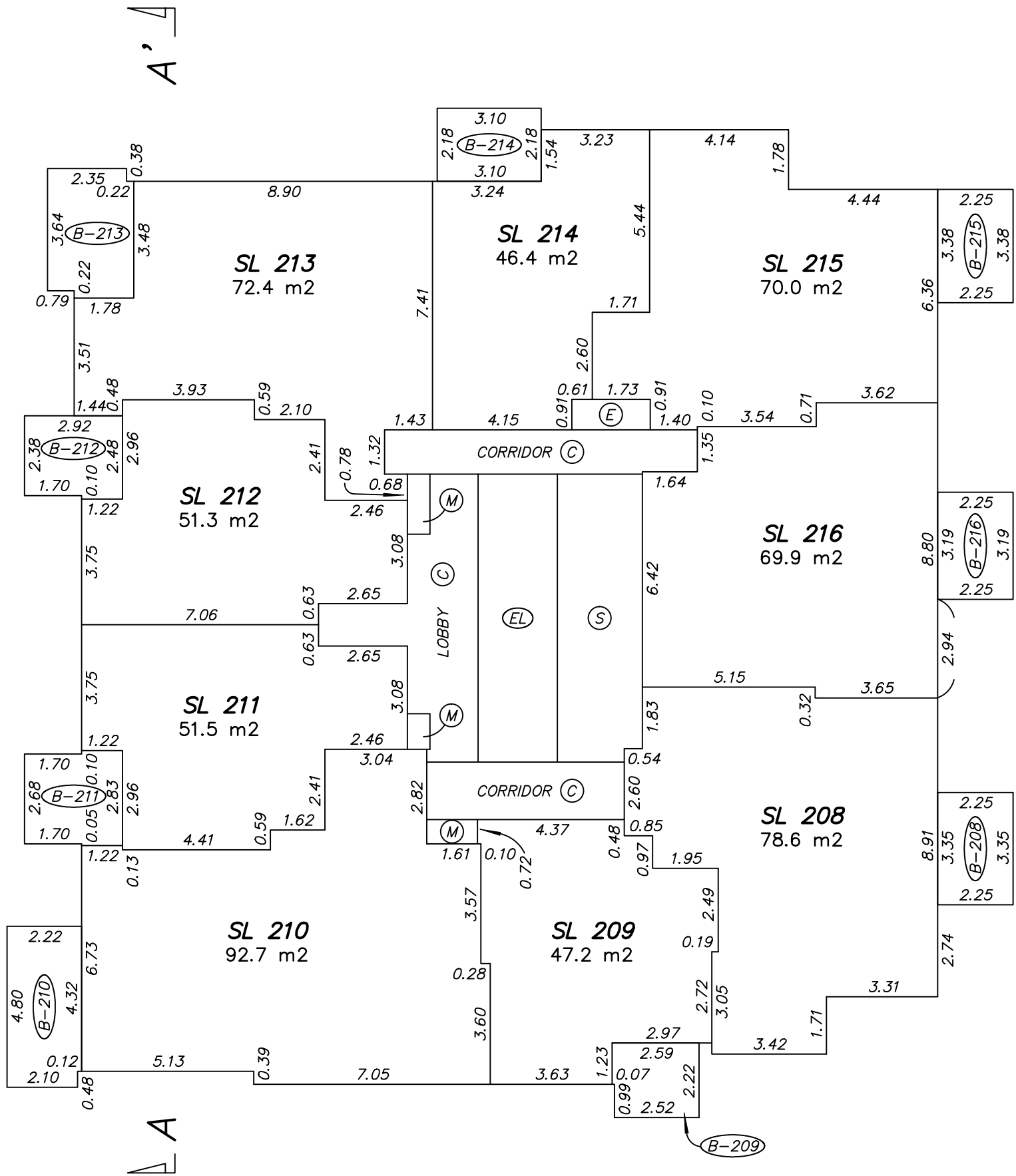
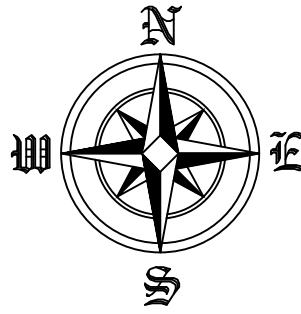

LEVEL 30

STRATA PLAN EPS4147

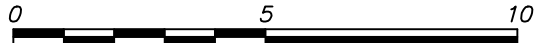

SCALE 1:150 DISTANCES ARE IN METRES

THE INTENDED PLOT SCALE OF THIS PLAN IS 280 mm IN WIDTH BY 432 mm IN HEIGHT (B SIZE) WHEN PLOTTED AT A SCALE OF 1:150.

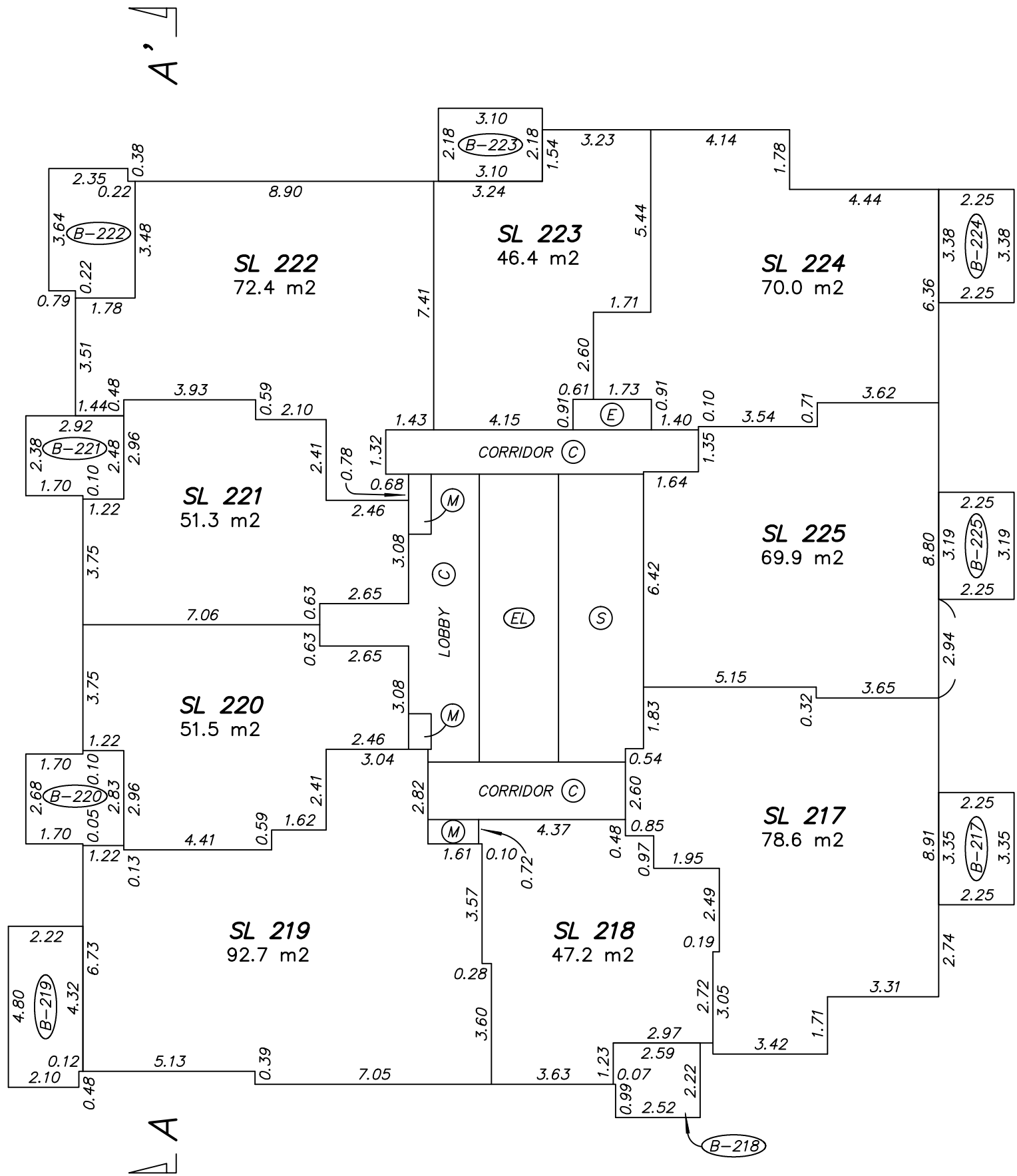
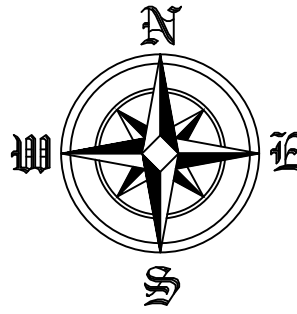

LEVEL 31

STRATA PLAN EPS4147

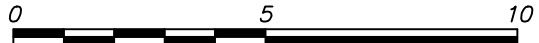

SCALE 1:150 DISTANCES ARE IN METRES

THE INTENDED PLOT SCALE OF THIS PLAN IS 280 mm IN WIDTH BY 432 mm IN HEIGHT (B SIZE) WHEN PLOTTED AT A SCALE OF 1:150.

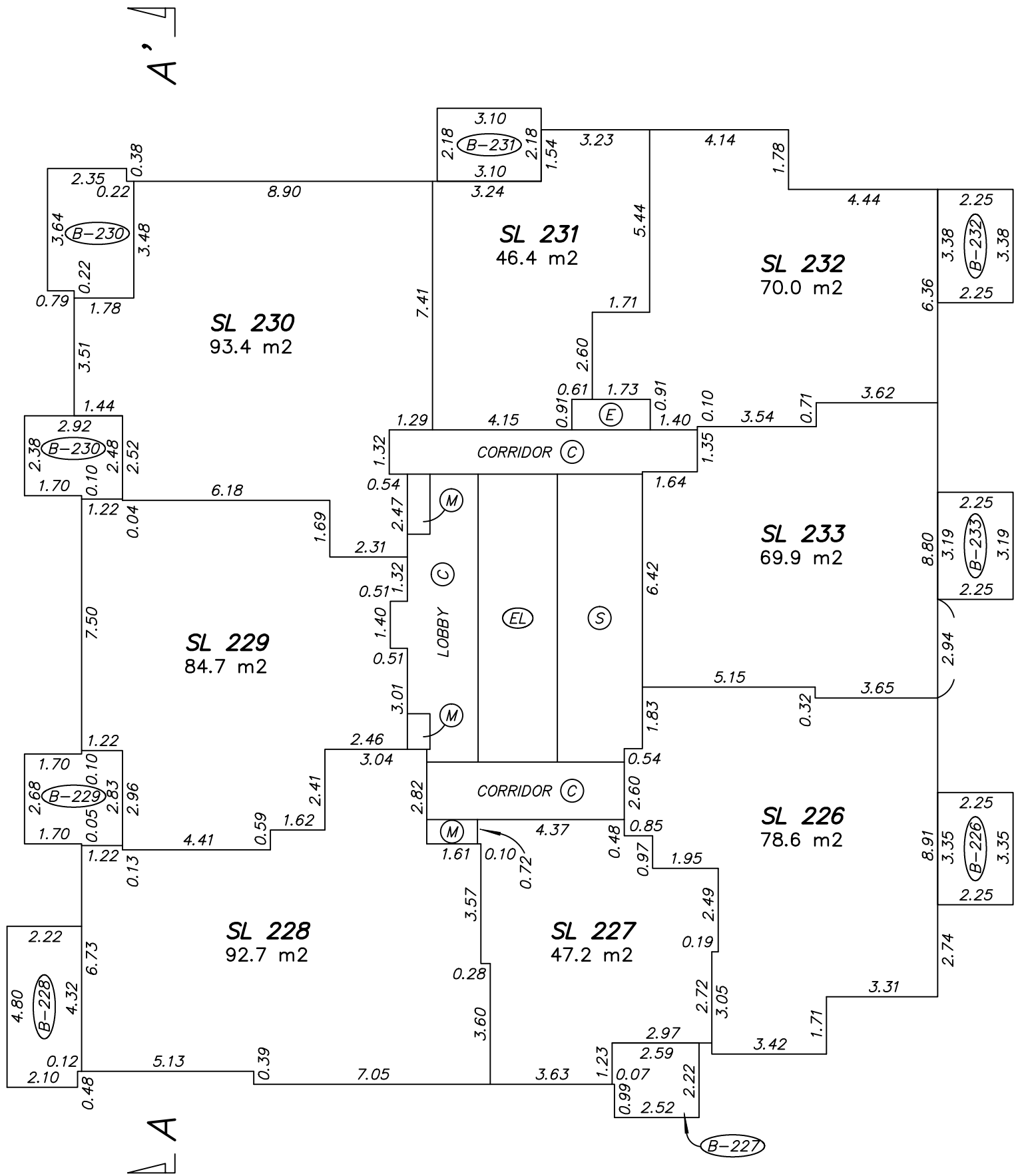
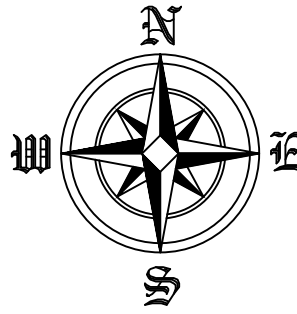

LEVEL 32

STRATA PLAN EPS4147

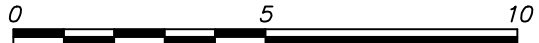

SCALE 1:150 DISTANCES ARE IN METRES

THE INTENDED PLOT SCALE OF THIS PLAN IS 280 mm IN WIDTH BY 432 mm IN HEIGHT (B SIZE) WHEN PLOTTED AT A SCALE OF 1:150.

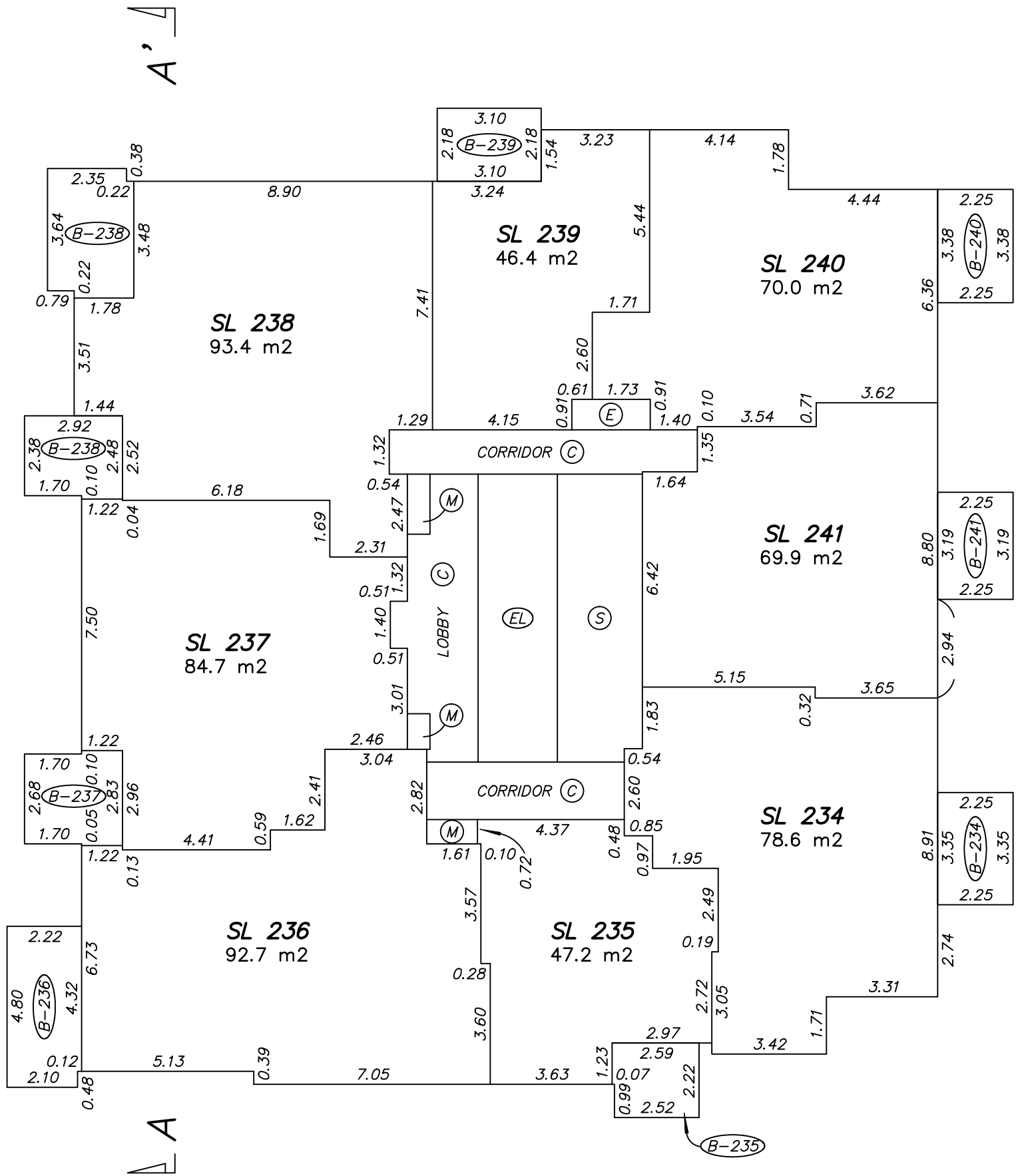
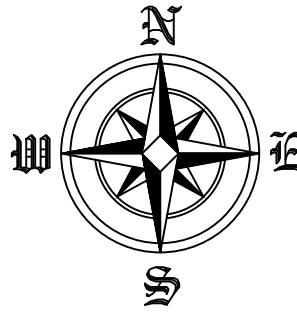

LEVEL 33

STRATA PLAN EPS4147

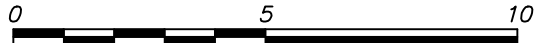

SCALE 1:150 DISTANCES ARE IN METRES

THE INTENDED PLOT SCALE OF THIS PLAN IS 280 mm IN WIDTH BY 432 mm IN HEIGHT (B SIZE) WHEN PLOTTED AT A SCALE OF 1:150.

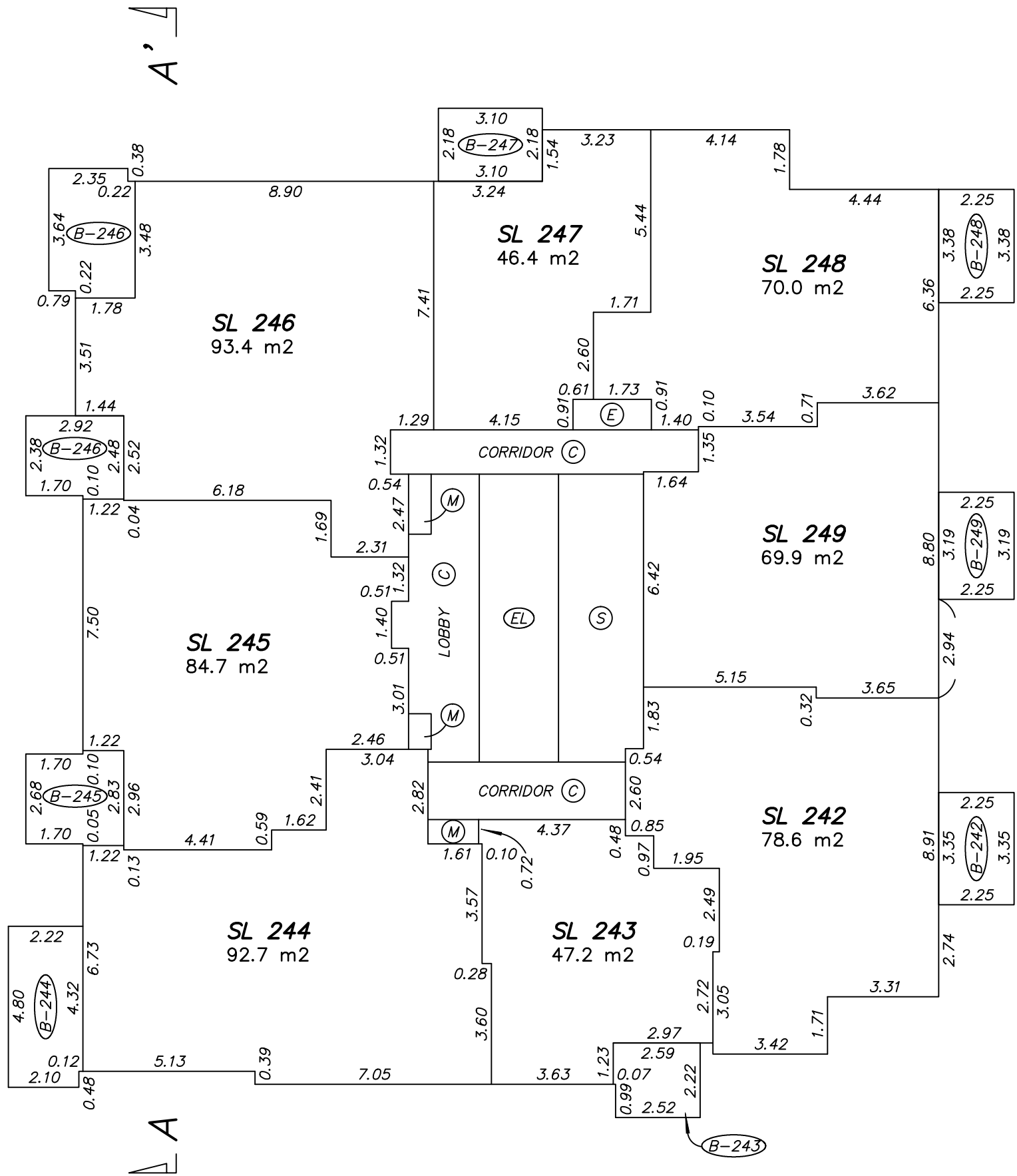
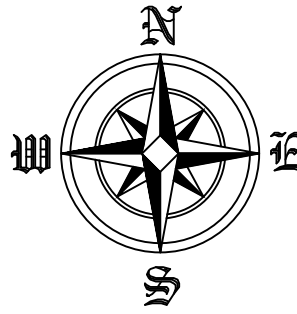

LEVEL 35

STRATA PLAN EPS4147

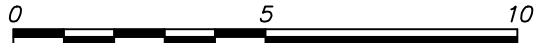

SCALE 1:150 DISTANCES ARE IN METRES

THE INTENDED PLOT SCALE OF THIS PLAN IS 280 mm IN WIDTH BY 432 mm IN HEIGHT (B SIZE) WHEN PLOTTED AT A SCALE OF 1:150.

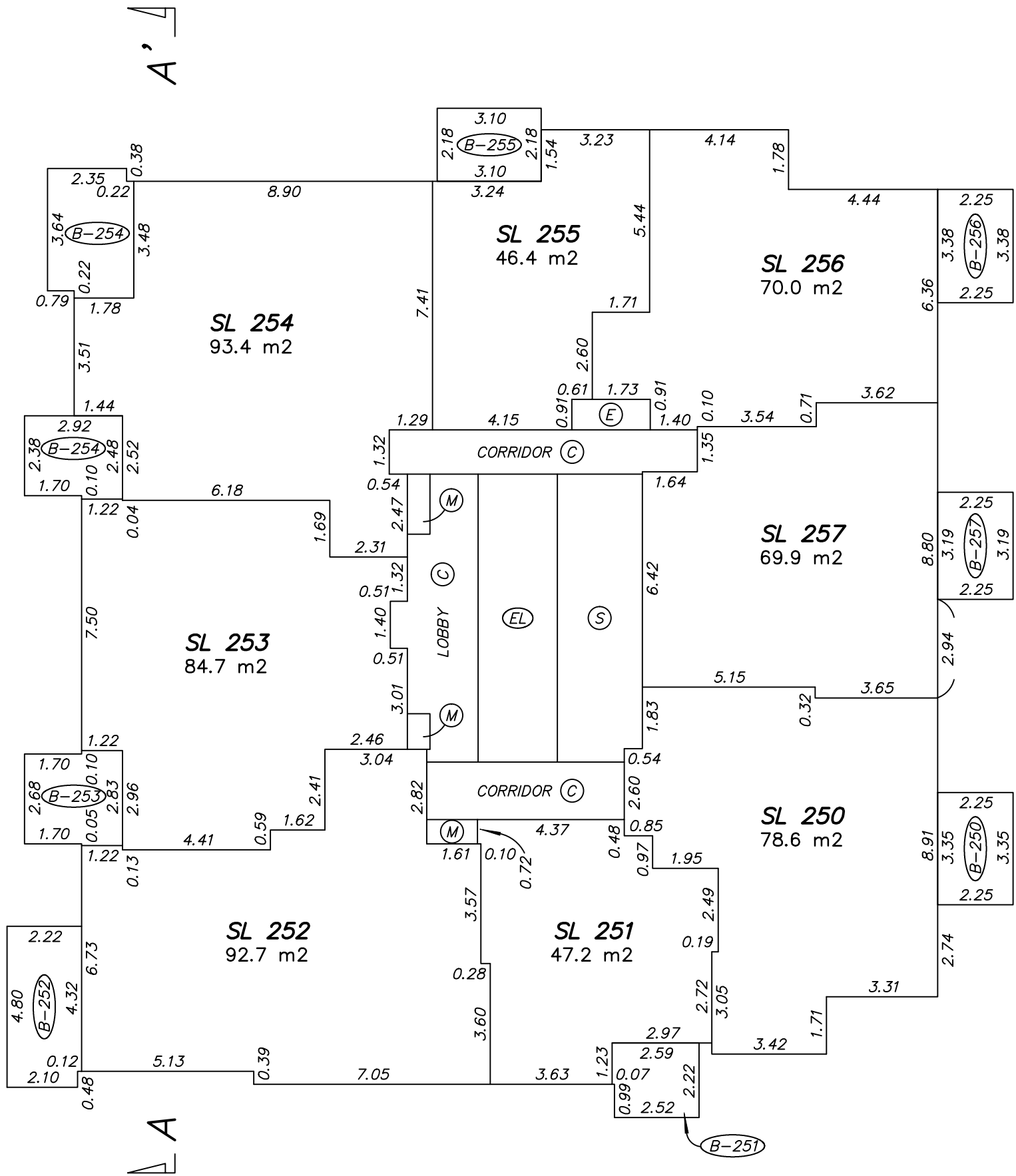
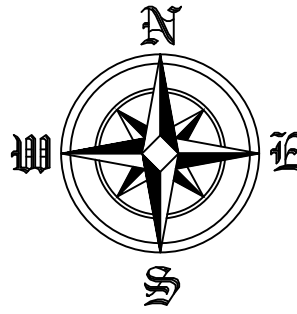

NOTE: THE 34th FLOOR HAS BEEN ELIMINATED FROM CONSECUTIVE FLOOR NUMBERING



JESSE MORIN, BCLS
Date: JUNE 6, 2017
File: 4413\Strata\Final
Dwg: 4413-FS-Rev.1

LEVEL 36

STRATA PLAN EPS4147

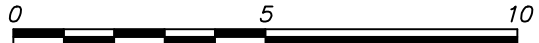

SCALE 1:150 DISTANCES ARE IN METRES

THE INTENDED PLOT SCALE OF THIS PLAN IS 280 mm IN WIDTH BY 432 mm IN HEIGHT (B SIZE) WHEN PLOTTED AT A SCALE OF 1:150.

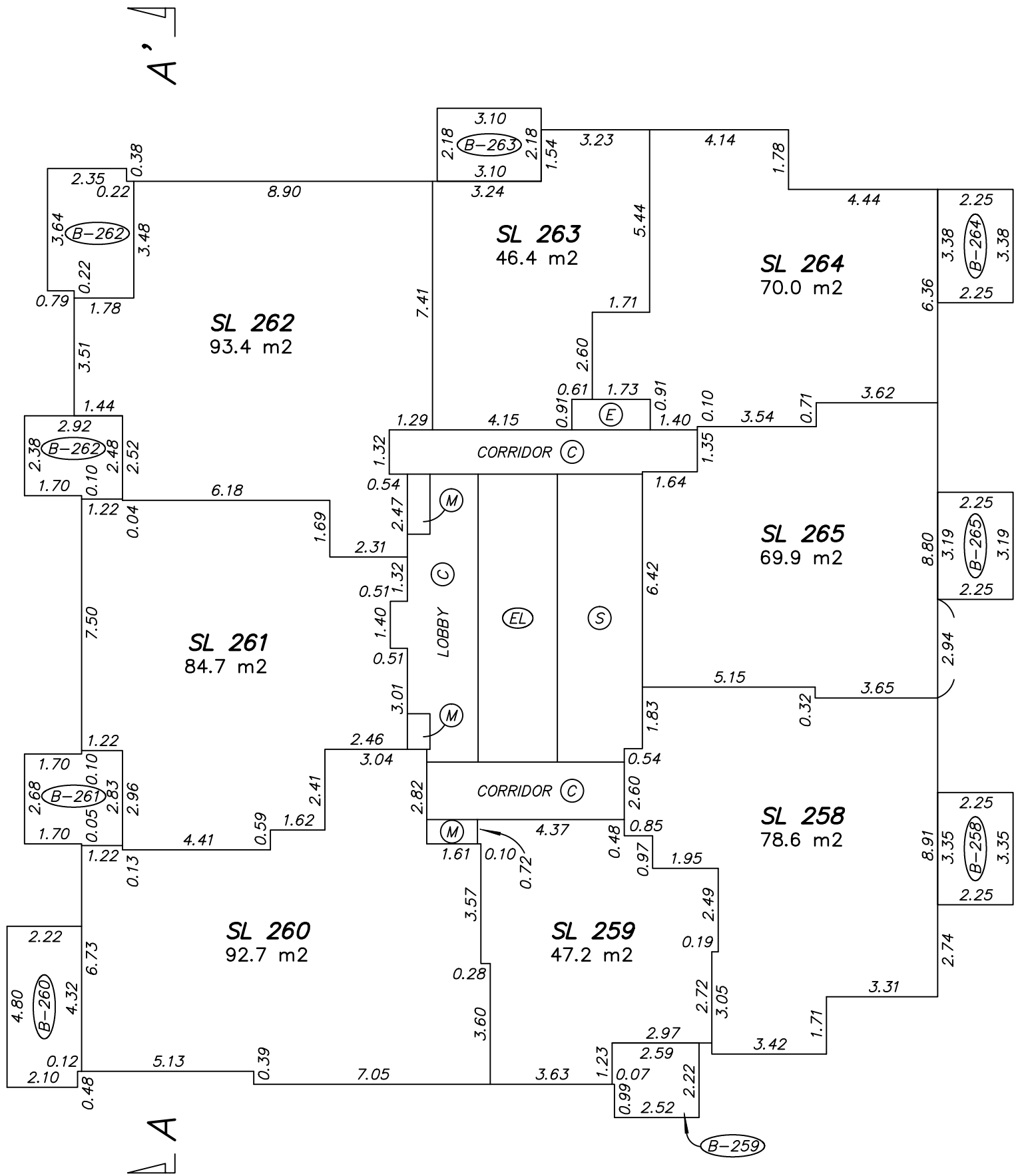
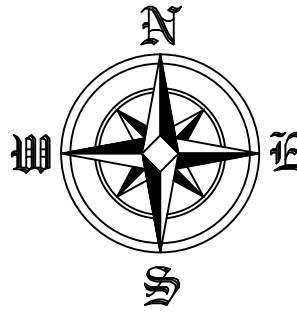

LEVEL 37

STRATA PLAN EPS4147

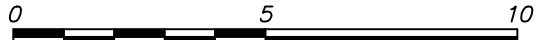

SCALE 1:150 DISTANCES ARE IN METRES

THE INTENDED PLOT SCALE OF THIS PLAN IS 280 mm IN WIDTH BY 432 mm IN HEIGHT (B SIZE) WHEN PLOTTED AT A SCALE OF 1:150.

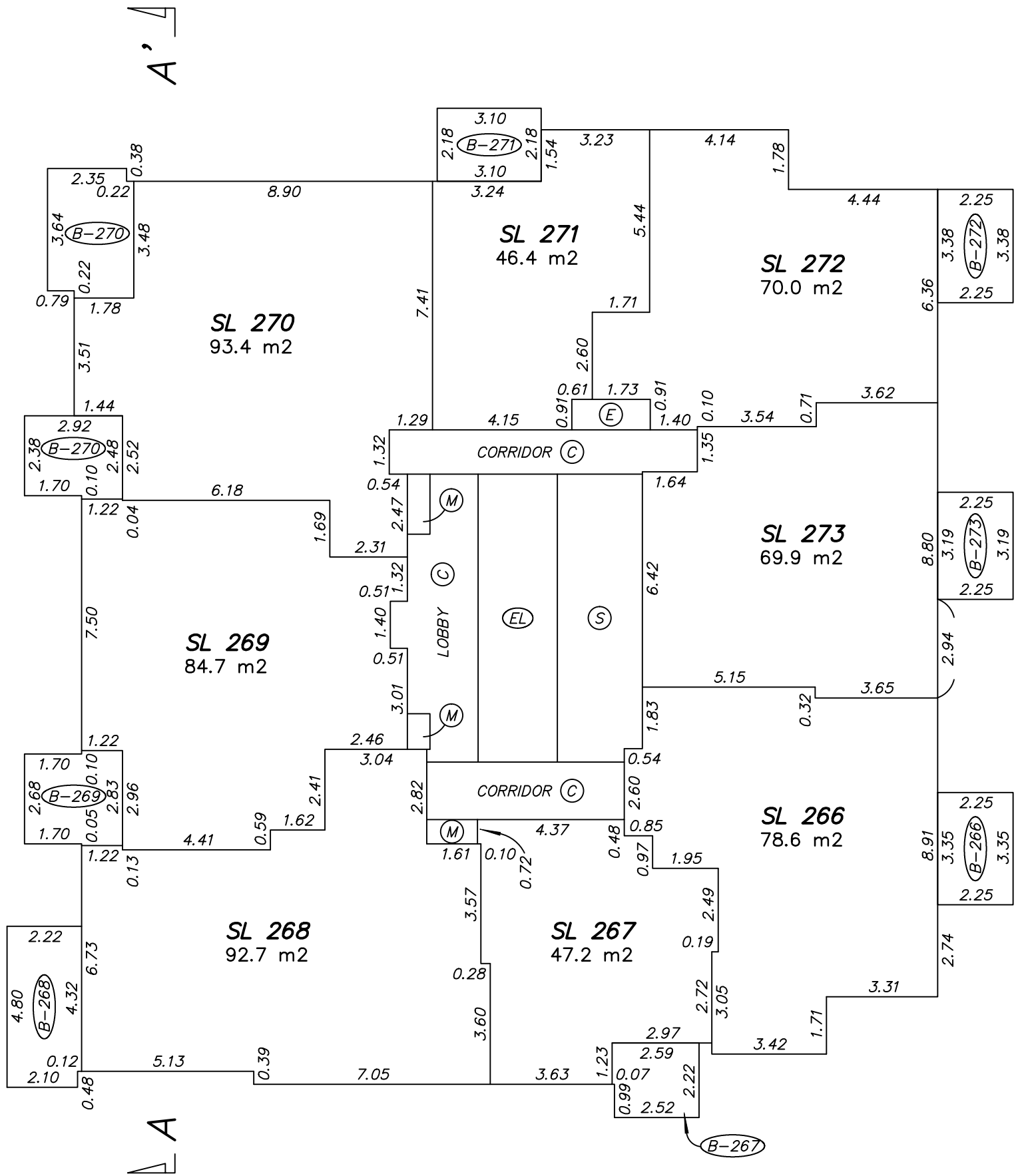
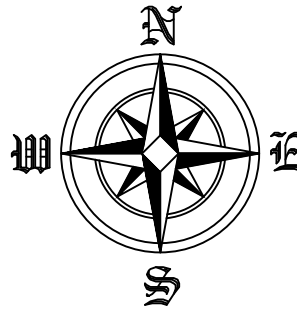

JESSE MORIN, BCLS
Date: JUNE 6, 2017
File: 4413\Strata\Final
Dwg: 4413-FS-Rev.1

LEVEL 38

STRATA PLAN EPS4147

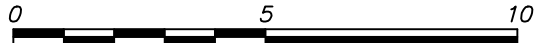

SCALE 1:150 DISTANCES ARE IN METRES

THE INTENDED PLOT SCALE OF THIS PLAN IS 280 mm IN WIDTH BY 432 mm IN HEIGHT (B SIZE) WHEN PLOTTED AT A SCALE OF 1:150.

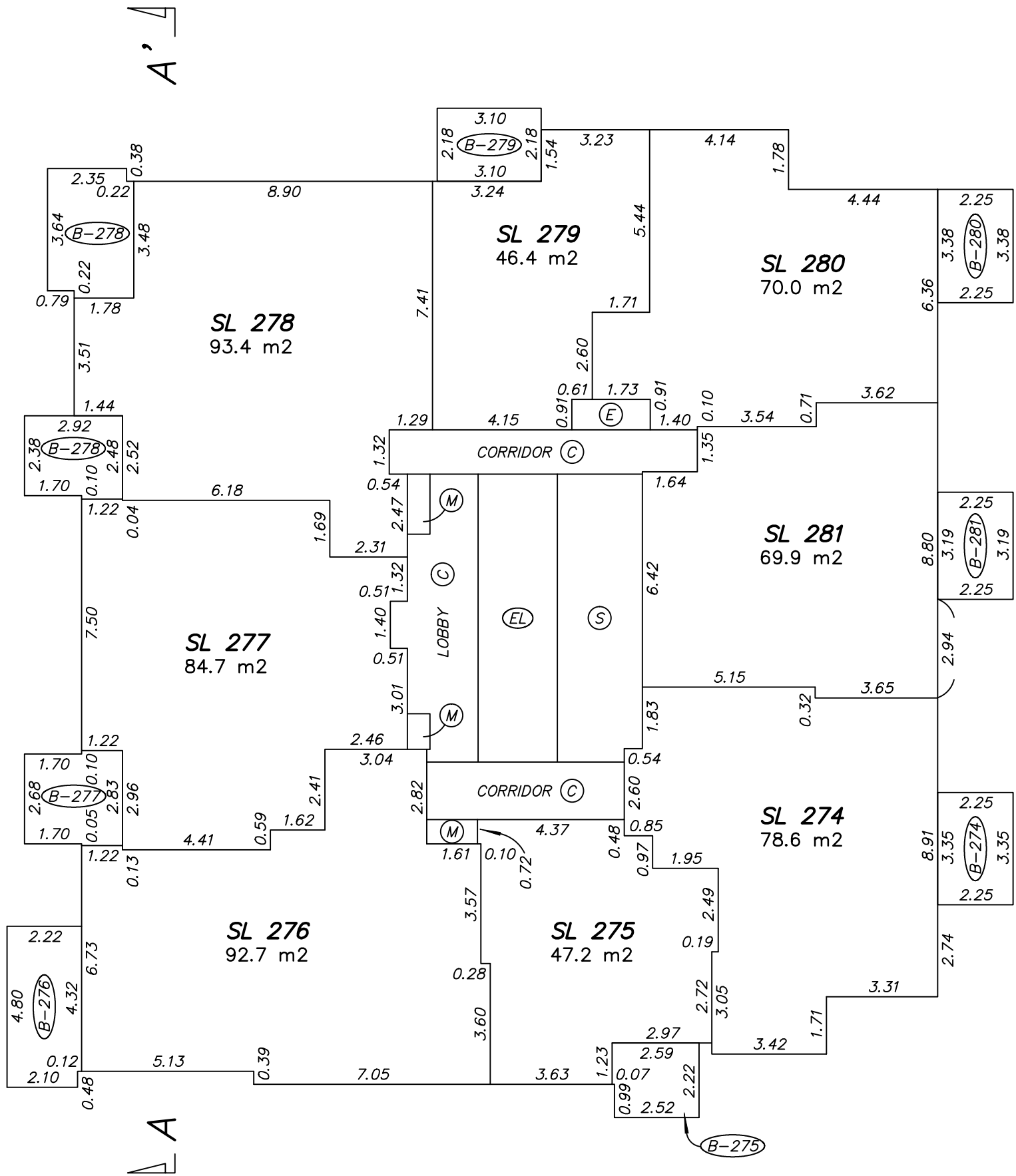
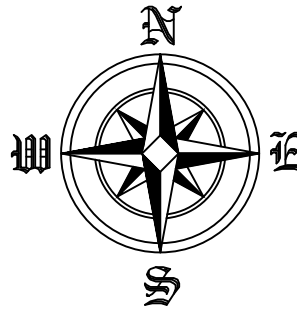

LEVEL 39

STRATA PLAN EPS4147

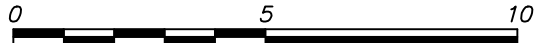

SCALE 1:150 DISTANCES ARE IN METRES

THE INTENDED PLOT SCALE OF THIS PLAN IS 280 mm IN WIDTH BY 432 mm IN HEIGHT (B SIZE) WHEN PLOTTED AT A SCALE OF 1:150.

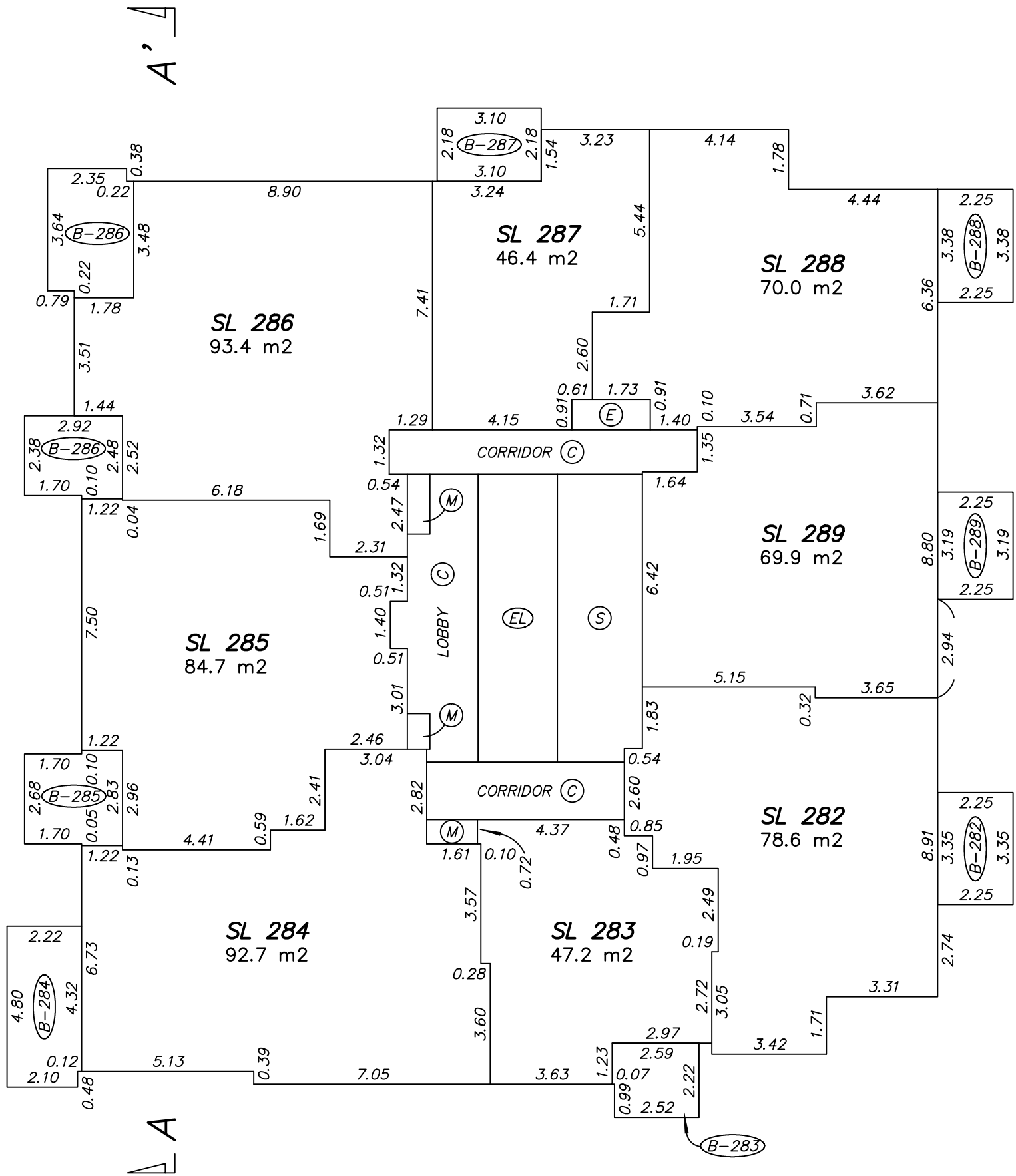
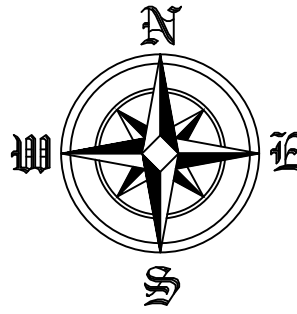

LEVEL 40

STRATA PLAN EPS4147

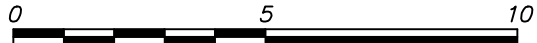

SCALE 1:150 DISTANCES ARE IN METRES

THE INTENDED PLOT SCALE OF THIS PLAN IS 280 mm IN WIDTH BY 432 mm IN HEIGHT (B SIZE) WHEN PLOTTED AT A SCALE OF 1:150.

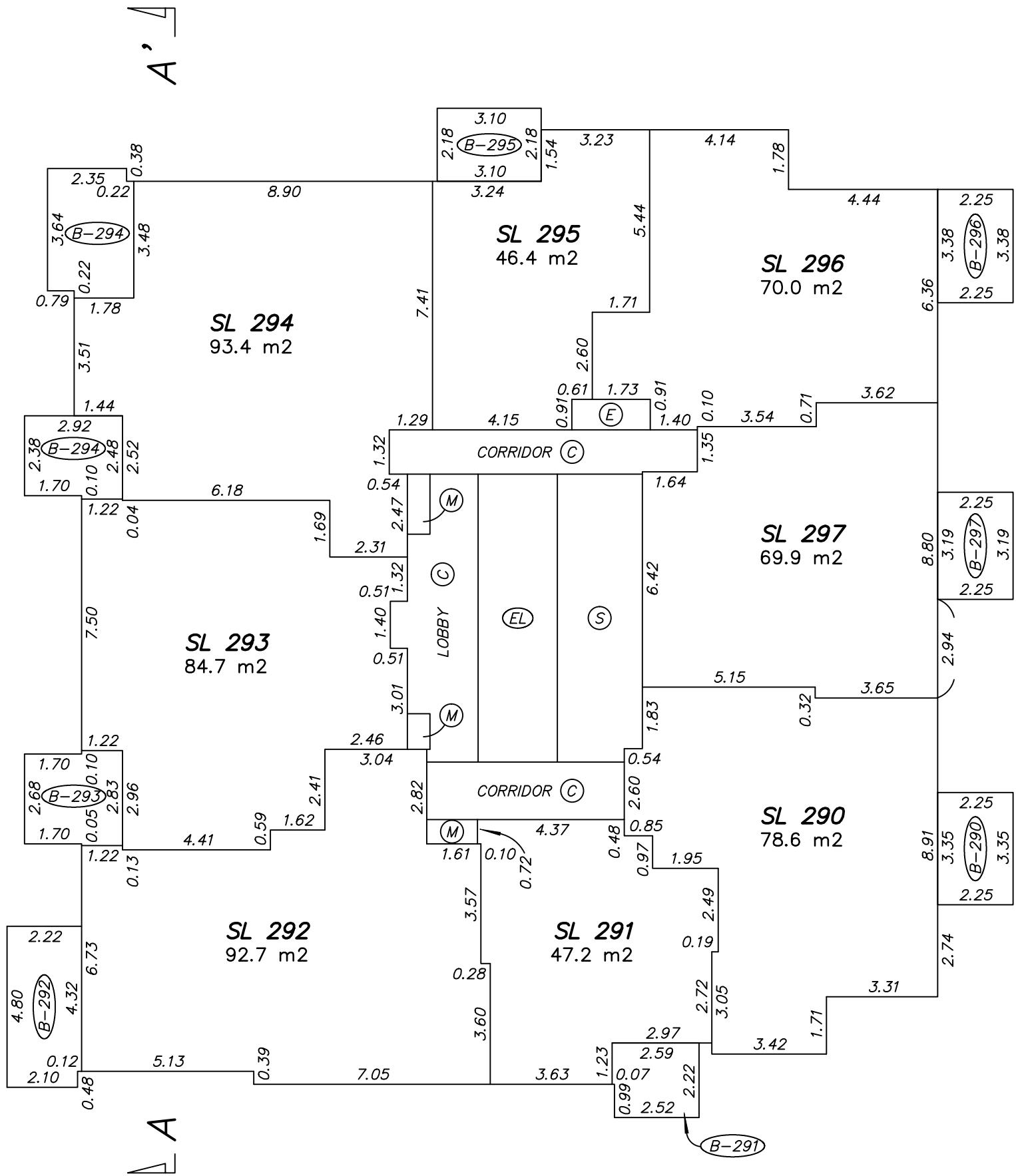
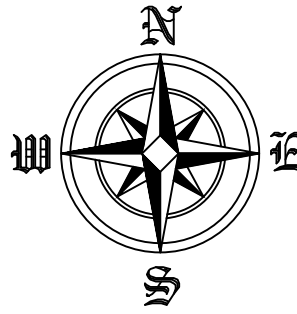

LEVEL 41

STRATA PLAN EPS4147

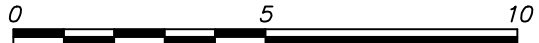

SCALE 1:150 DISTANCES ARE IN METRES

THE INTENDED PLOT SCALE OF THIS PLAN IS 280 mm IN WIDTH BY 432 mm IN HEIGHT (B SIZE) WHEN PLOTTED AT A SCALE OF 1:150.

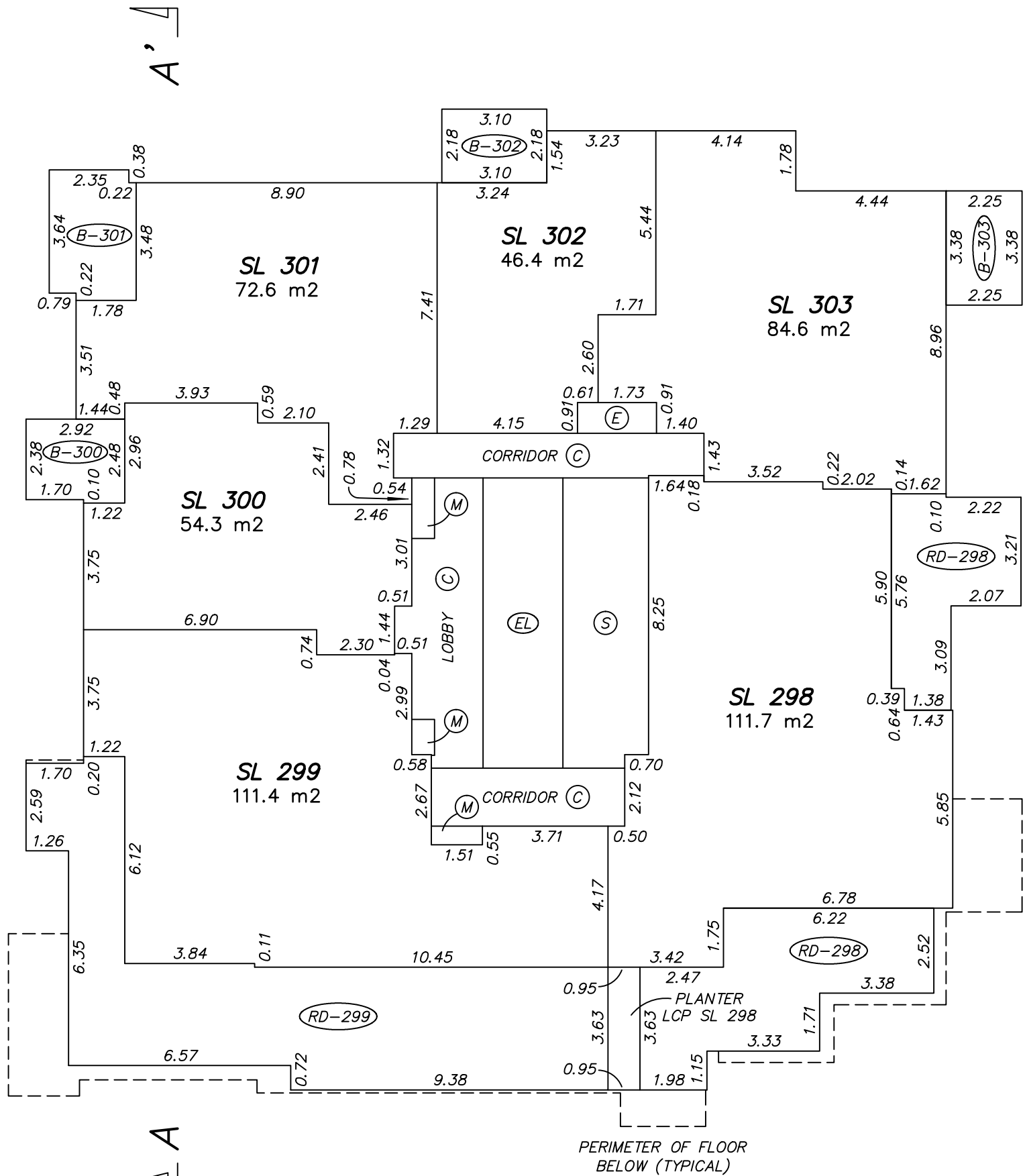
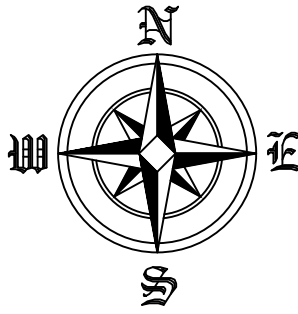

LEVEL 42

STRATA PLAN EPS4147

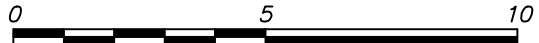

SCALE 1:150 DISTANCES ARE IN METRES

THE INTENDED PLOT SCALE OF THIS PLAN IS 280 mm IN WIDTH BY 432 mm IN HEIGHT (B SIZE) WHEN PLOTTED AT A SCALE OF 1:150.

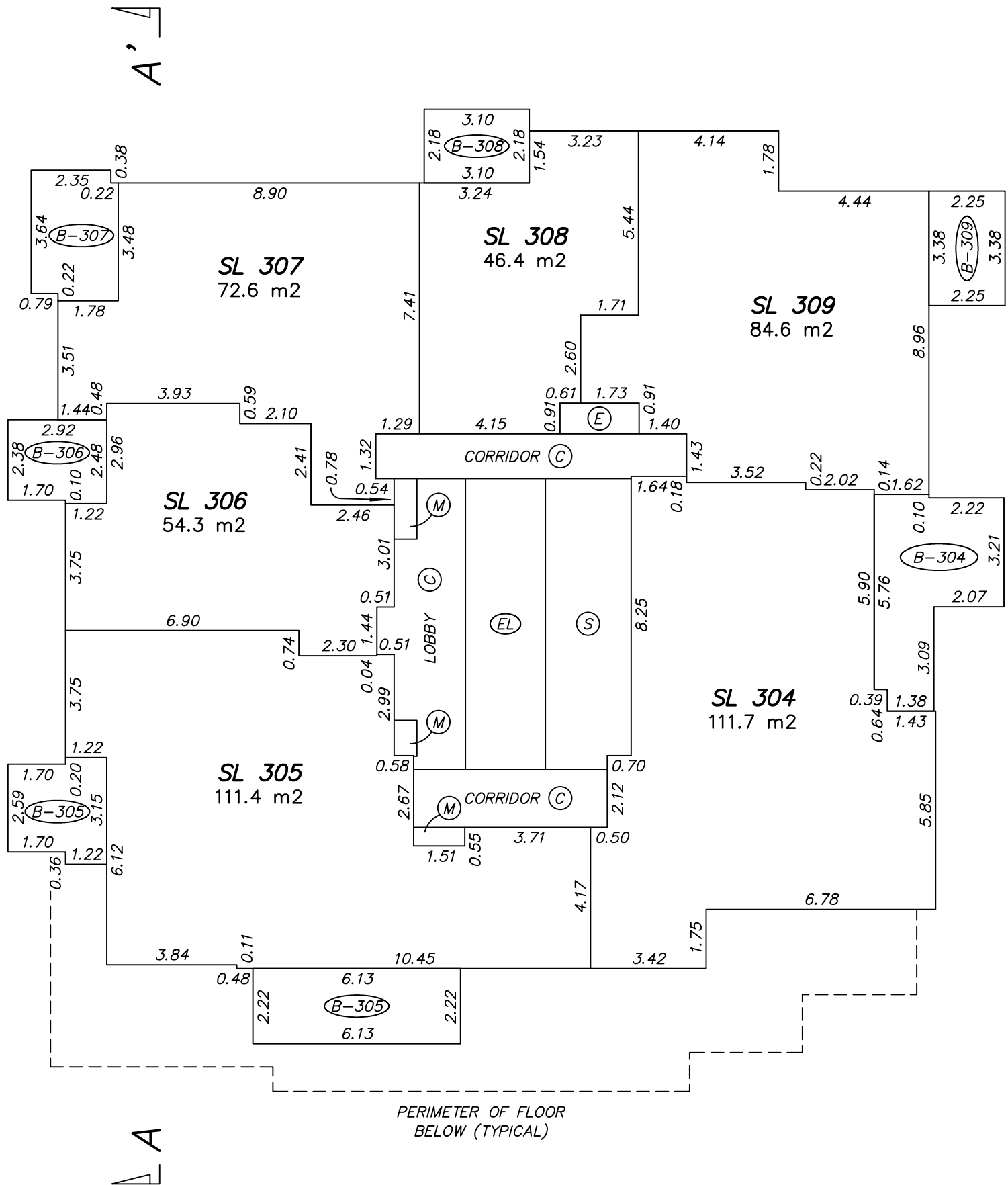
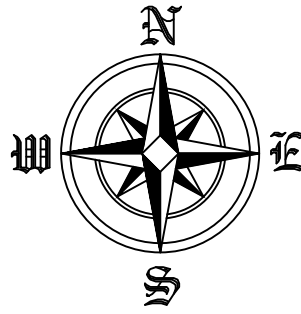

LEVEL 43

STRATA PLAN EPS4147

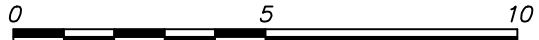

SCALE 1:150 DISTANCES ARE IN METRES

THE INTENDED PLOT SCALE OF THIS PLAN IS 280 mm IN WIDTH BY 432 mm IN HEIGHT (B SIZE) WHEN PLOTTED AT A SCALE OF 1:150.

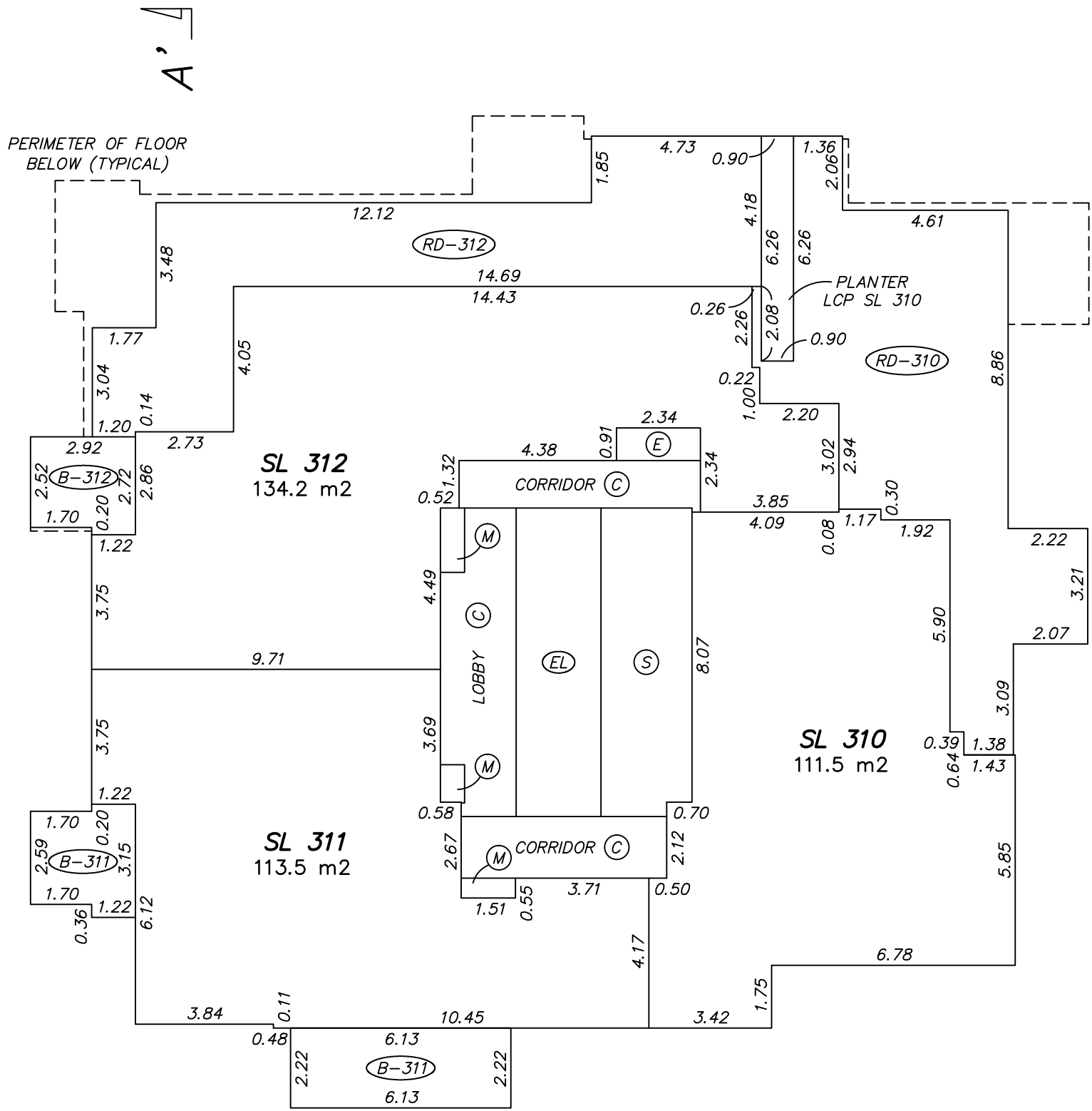
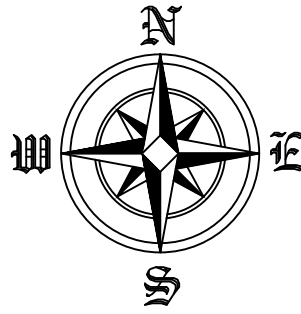

JESSE MORIN, BCLS
Date: JUNE 6, 2017
File: 4413\Strata\Final
Dwg: 4413-FS-Rev.1

ROOF LEVEL

STRATA PLAN EPS4147

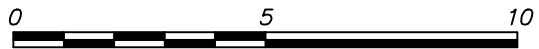

SCALE 1:150 DISTANCES ARE IN METRES

THE INTENDED PLOT SCALE OF THIS PLAN IS 280 mm IN WIDTH BY 432 mm IN HEIGHT (B SIZE) WHEN PLOTTED AT A SCALE OF 1:150.

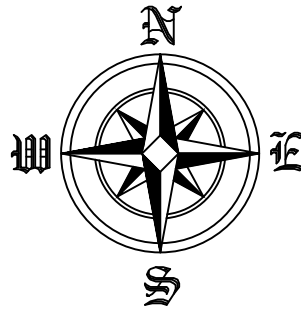

A' ↙

PERIMETER OF FLOOR BELOW (TYPICAL)

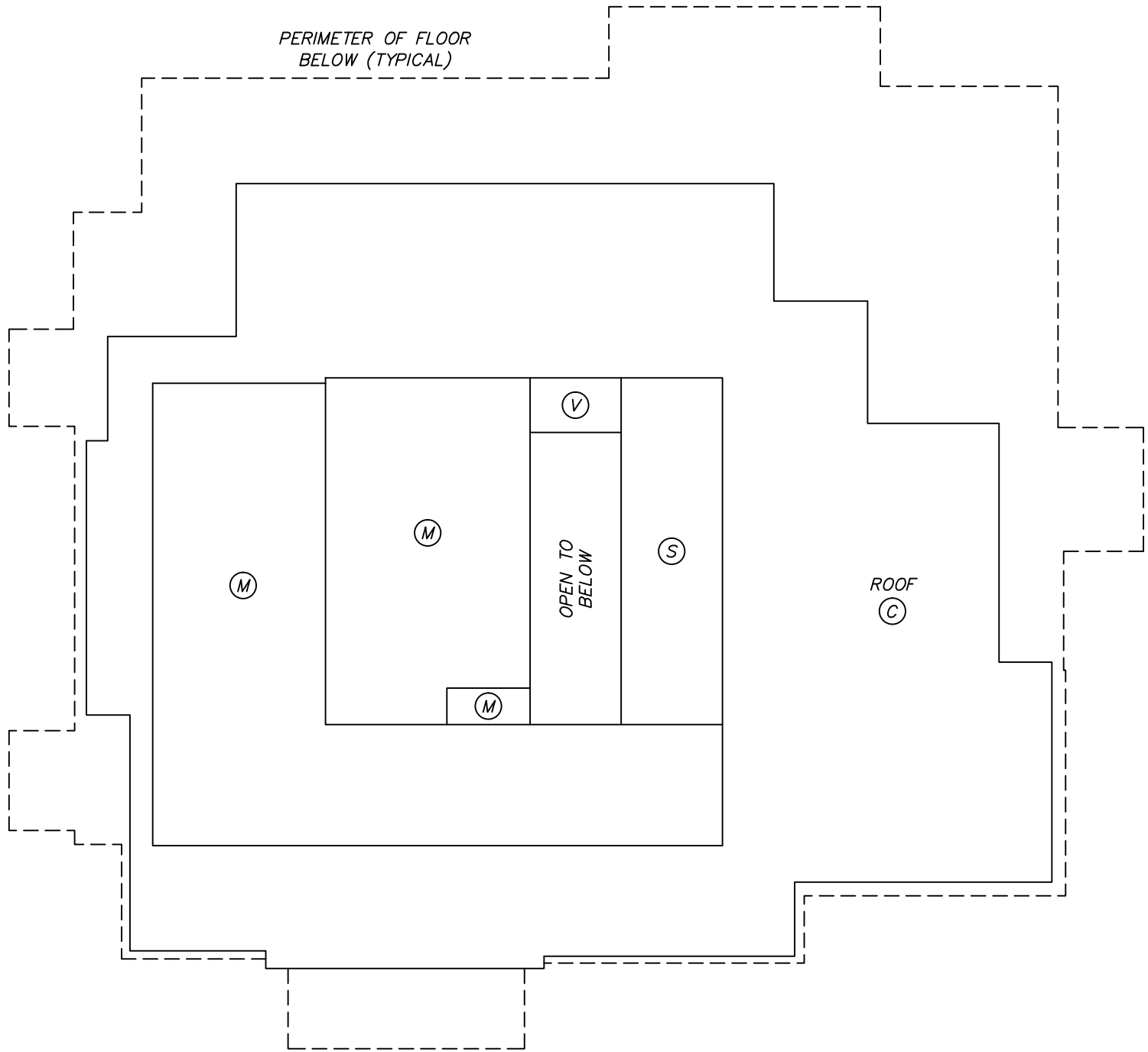

↘ A



JESSE MORIN, BCLS
Date: JUNE 6, 2017
File: 4413\Strata\Final
Dwg: 4413-FS-Rev.1

SECTION A-A'

STRATA PLAN EPS4147



SCALE 1:200 DISTANCES ARE IN METRES

THE INTENDED PLOT SCALE OF THIS PLAN IS 280 mm IN WIDTH BY 432 mm IN HEIGHT (B SIZE) WHEN PLOTTED AT A SCALE OF 1:200.

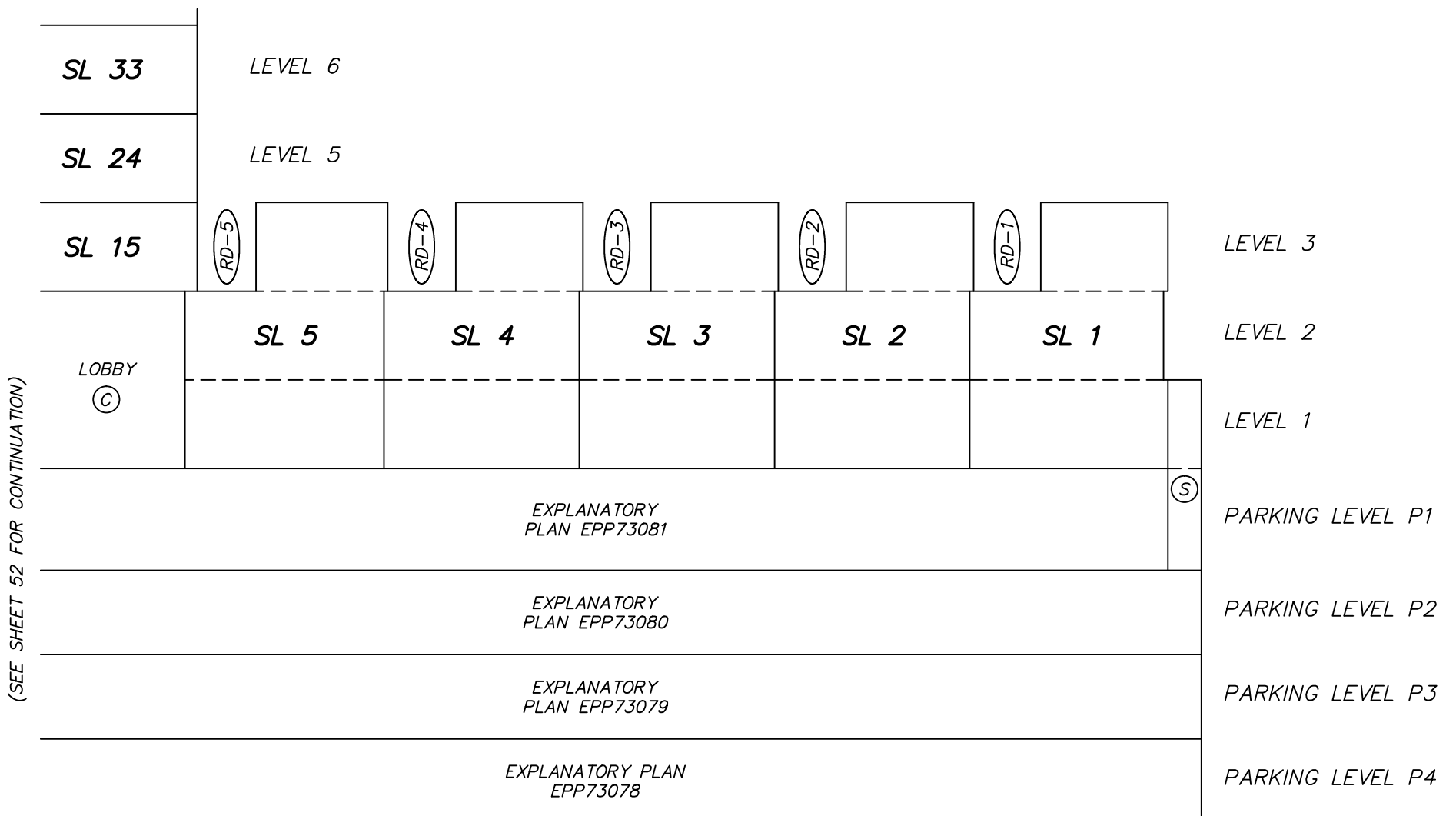

JESSE MORIN, BCLS
 Date: JUNE 6, 2017
 File: 4413\Strata\Final
 Dwg: 4413-FS-Rev.1

SECTION A-A'

STRATA PLAN EPS4147



SCALE 1:200 DISTANCES ARE IN METRES

THE INTENDED PLOT SCALE OF THIS PLAN IS 280 mm IN WIDTH BY 432 mm IN HEIGHT (B SIZE) WHEN PLOTTED AT A SCALE OF 1:200.

(SEE SHEET 53 FOR CONTINUATION)

		SL 147	SL 148	SL 149	SL 150	LEVEL 21
		SL 138	SL 139	SL 140	SL 141	LEVEL 20
		SL 129	SL 130	SL 131	SL 132	LEVEL 19
		SL 120	SL 121	SL 122	SL 123	LEVEL 18
		SL 111	SL 112	SL 113	SL 114	LEVEL 17
		SL 102	SL 103	SL 104	SL 105	LEVEL 16
		SL 93	SL 94	SL 95	SL 96	LEVEL 15
		SL 84	SL 85	SL 86	SL 87	LEVEL 12
		SL 75	SL 76	SL 77	SL 78	LEVEL 11
		SL 66	SL 67	SL 68	SL 69	LEVEL 10
		SL 57	SL 58	SL 59	SL 60	LEVEL 9
		SL 48	SL 49	SL 50	SL 51	LEVEL 8
		SL 39	SL 40	SL 41	SL 42	LEVEL 7
		SL 30	SL 31	SL 32	SL 33	LEVEL 6
		SL 21	SL 22	SL 23	SL 24	LEVEL 5
	(RD-21)	SL 11	SL 12	SL 13	SL 14	SL 15
LEVEL 3						(RD-5)
LEVEL 2		SL 8	SL 7	SL 6		SL 5
LEVEL 1					LOBBY (C)	

(SEE SHEET 51 FOR CONTINUATION)

	EXPLANATORY PLAN EPP73081	PARKING LEVEL P1
PARKING (C)	EXPLANATORY PLAN EPP73080	PARKING LEVEL P2
	EXPLANATORY PLAN EPP73079	PARKING LEVEL P3
	EXPLANATORY PLAN EPP73078	PARKING LEVEL P4

SECTION A-A'

STRATA PLAN EPS4147



SCALE 1:200 DISTANCES ARE IN METRES

THE INTENDED PLOT SCALE OF THIS PLAN IS 280 mm IN WIDTH BY 432 mm IN HEIGHT (B SIZE) WHEN PLOTTED AT A SCALE OF 1:200.

ROOF		(M)		ROOF		ROOF LEVEL
ROOF		(C)		ROOF		
SL 311		SL 312		(RD-312)		LEVEL 43
SL 305		SL 306		SL 307		LEVEL 42
SL 299		SL 300		SL 301		LEVEL 41
(RD-299)						
SL 292	SL 293		SL 294			LEVEL 40
SL 284	SL 285		SL 286			LEVEL 39
SL 276	SL 277		SL 278			LEVEL 38
SL 268	SL 269		SL 270			LEVEL 37
SL 260	SL 261		SL 262			LEVEL 36
SL 252	SL 253		SL 254			LEVEL 35
SL 244	SL 245		SL 246			LEVEL 33
SL 236	SL 237		SL 238			LEVEL 32
SL 228	SL 229		SL 230			LEVEL 31
SL 219	SL 220	SL 221	SL 222			LEVEL 30
SL 210	SL 211	SL 212	SL 213			LEVEL 29
SL 201	SL 202	SL 203	SL 204			LEVEL 28
SL 192	SL 193	SL 194	SL 195			LEVEL 27
SL 183	SL 184	SL 185	SL 186			LEVEL 26
SL 174	SL 175	SL 176	SL 177			LEVEL 25
SL 165	SL 166	SL 167	SL 168			LEVEL 23
SL 156	SL 157	SL 158	SL 159			LEVEL 22
SL 147	SL 148	SL 149	SL 150			LEVEL 21
SL 138	SL 139	SL 140	SL 141			LEVEL 20

(SEE SHEET 52 FOR CONTINUATION)



JESSE MORIN, BCLS
 Date: JUNE 6, 2017
 File: 4413\Strata\Final
 Dwg: 4413-FS-Rev.1