

# BC OnLine

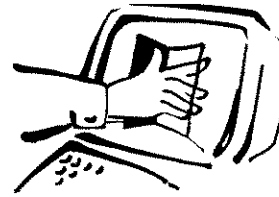

BC OnLine Land Title Internet Service  
Provided in co-operation with  
Land Title and Survey Authority

-----

LTSA - DOCUMENT RETRIEVAL	REF# I97436	REQUESTED:2009-04-06 09:01
CLIENT NAME:	RE/MAX REAL ESTATE SERVICES AS	
ADDRESS:	REALTY LTD. 410-650 WEST 41ST AVE NORTH OFFICE TOWER VANCOUVER BC V5Z 2M9	
PICK-UP INSTRUCTIONS:		
USER ID: PA74746	PLAN# VAS2116	VA Filed RCVD:1998-02-26
ACCOUNT: 199822		
FOLIO SWYATT		
REMARKS:		

-----

Help Desk Victoria ..... (250) 953-8200  
                  In B.C. .... 1-800-663-6102  
Administration Office ... (250) 953-8250  
Fax Number ..... (250) 953-8222

Persons who need to rely on a plan for legal purposes must examine the official version at the Land Title Office in which the plan is deposited. However, plans with plan numbers beginning with the letters EPP or EPS are electronic plans which constitute the official version.

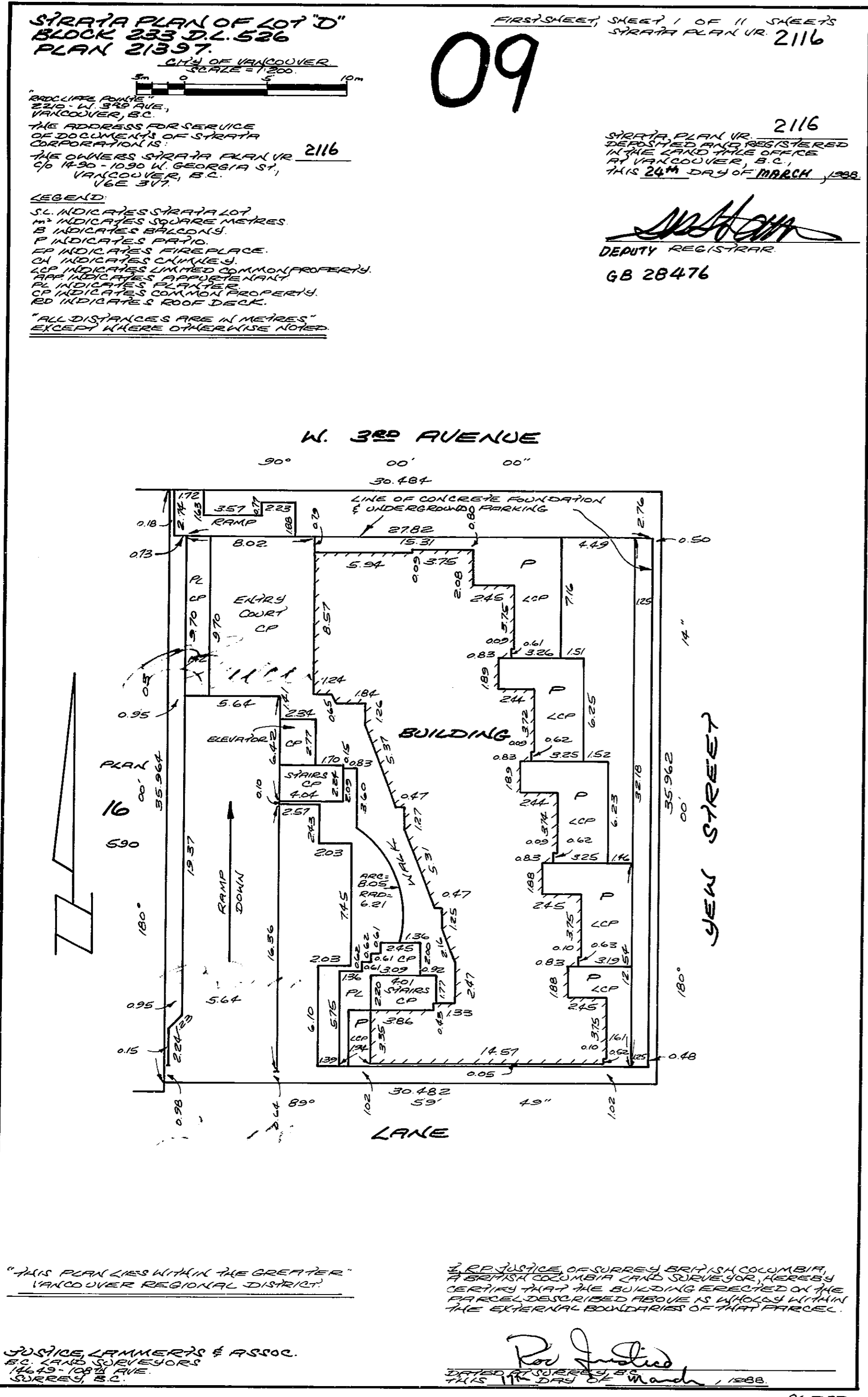

### CONDOMINIUM ACT

LOT NUMBER	SHEET NUMBER	FORM 1 SCHEDULE OF UNIT ENTITLEMENT	FORM 2 SCHEDULE OF INTEREST UPON DESTRUCTION	FORM 3 SCHEDULE OF VOTING RIGHTS
1	5	76	124	
2	5	58	104	
3	5	55	97	
4	5	50	87	
5	5	69	112	
6	6	74	118	
7	6	79	124	
8	6	60	104	
9	6	56	98	
10	6	51	87	
11	6	71	119	
12	7	74	135	
13	7	79	133	
14	7	60	108	
15	7	56	101	
16	7	51	90	
17	7	71	127	
18	8	74	143	
19	8	69	141	
20	8	60	115	
21	8	56	108	
22	8	51	94	
23	8	71	135	
AGGREGATE		1471	2606	

STATUTORY DECLARATION

I, THE UNDERSIGNED DO SOLEMNLY DECLARE THAT:

(1) I, THE UNDERSIGNED AM THE DULY AUTHORIZED AGENT OF THE OWNER-DEVELOPER.

(2) THE STRATA PLAN IS ENTIRELY FOR RESIDENTIAL USE.

I MAKE THIS SOLEMN DECLARATION CONSCIENTIOUSLY BELIEVING IT TO BE TRUE AND KNOWING THAT IT IS OF THE SAME FORCE AND EFFECT AS IF MADE UNDER OATH.

RP JUSTICE OF SURREY, BRITISH COLUMBIA, HEREBY CERTIFY THAT THE BUILDING SHOWN IN THIS STRATA PLAN WAS NOT AN OF THIS 17<sup>TH</sup> DAY OF MARCH, 1988 BEEN PREVIOUSLY OCCUPIED DATED AT SURREY, BRITISH COLUMBIA, THIS 17<sup>TH</sup> DAY OF MARCH, 1988

ACCEPTED AS TO FORMS 1, 2 AND 3 THIS 27 DAY OF MARCH 1988

RP SUPERINTENDENT OF REAL ESTATE

OWNERS:

BUCCI DEVELOPMENT CORPORATION  
 WESTERN BUILDERS CAPITAL LIMITED

RP JUSTICE OF SURREY, BRITISH COLUMBIA, HEREBY CERTIFY THAT THE BUILDING SHOWN IN THIS STRATA PLAN WAS NOT AN OF THIS 17<sup>TH</sup> DAY OF MARCH, 1988 BEEN PREVIOUSLY OCCUPIED DATED AT SURREY, BRITISH COLUMBIA, THIS 17<sup>TH</sup> DAY OF MARCH, 1988

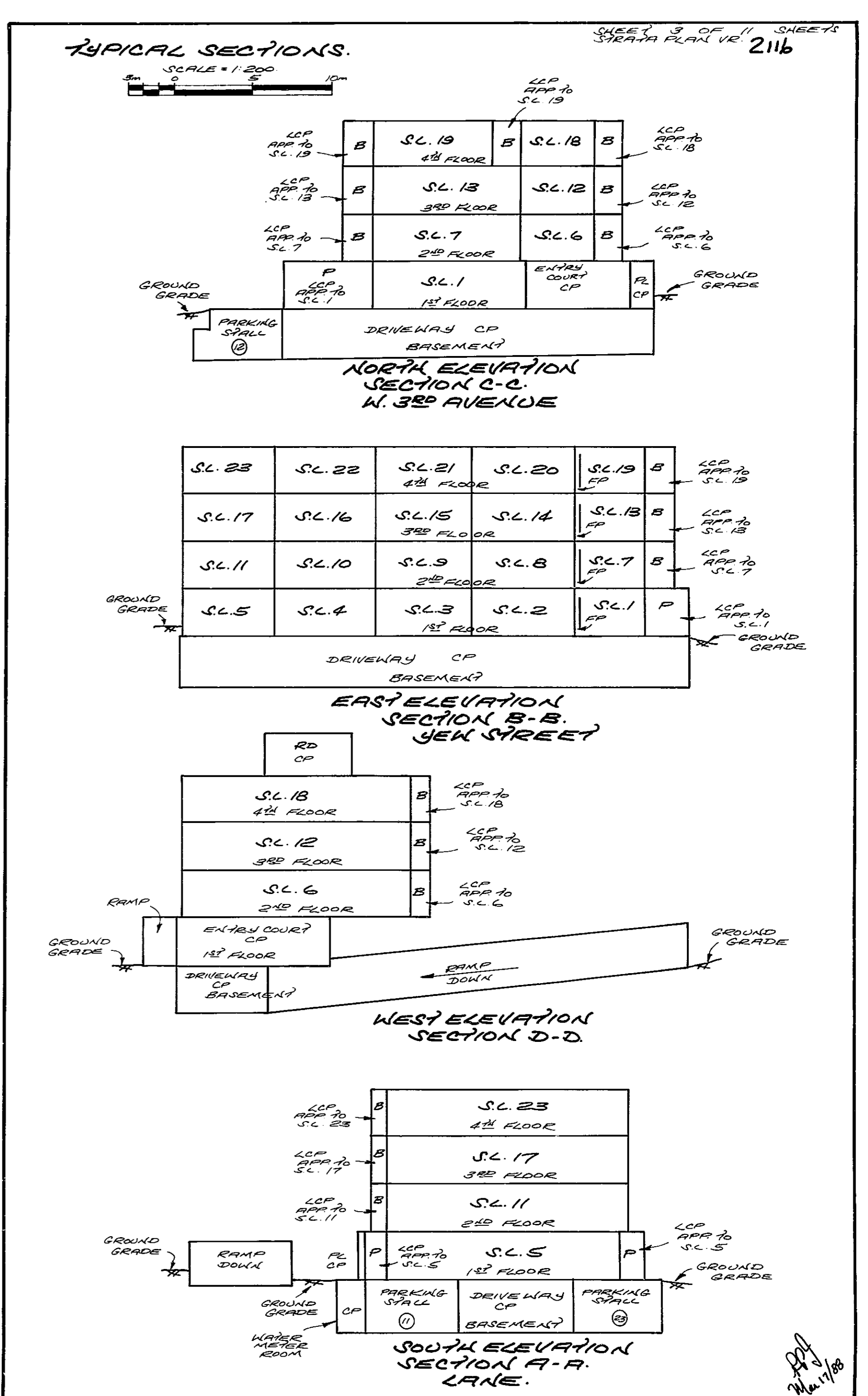



**BASEMENT?  
COMMON PROPERTY.**

SCALE = 1:200.  
0 5 10m

"ALL ANGLES ARE 90° OR 45° UNLESS OTHERWISE NOTED."

SHEET 4 OF 11 SHEETS  
STRATA PLAN VR 2116

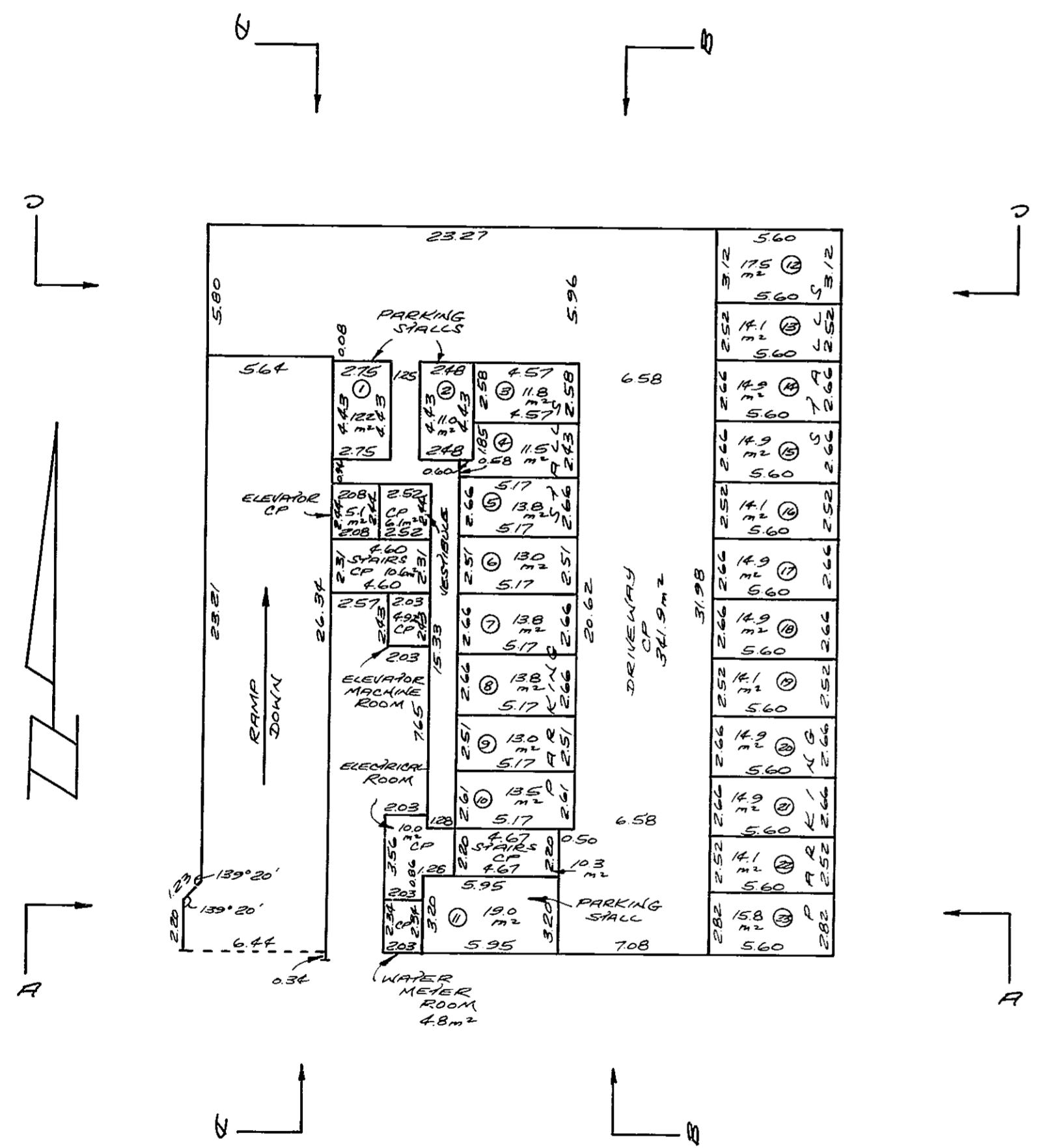

DDP  
Mar 17/08

86232

**FIRST FLOOR.  
STRATA LOTS 170-5 INCLUSIVE.**

SCALE = 1:200.  
0 5 10m

"ALL ANGLES ARE 90° OR 45° UNLESS OTHERWISE NOTED."

SHEET 5 OF 11 SHEETS  
STRATA PLAN VR 2116

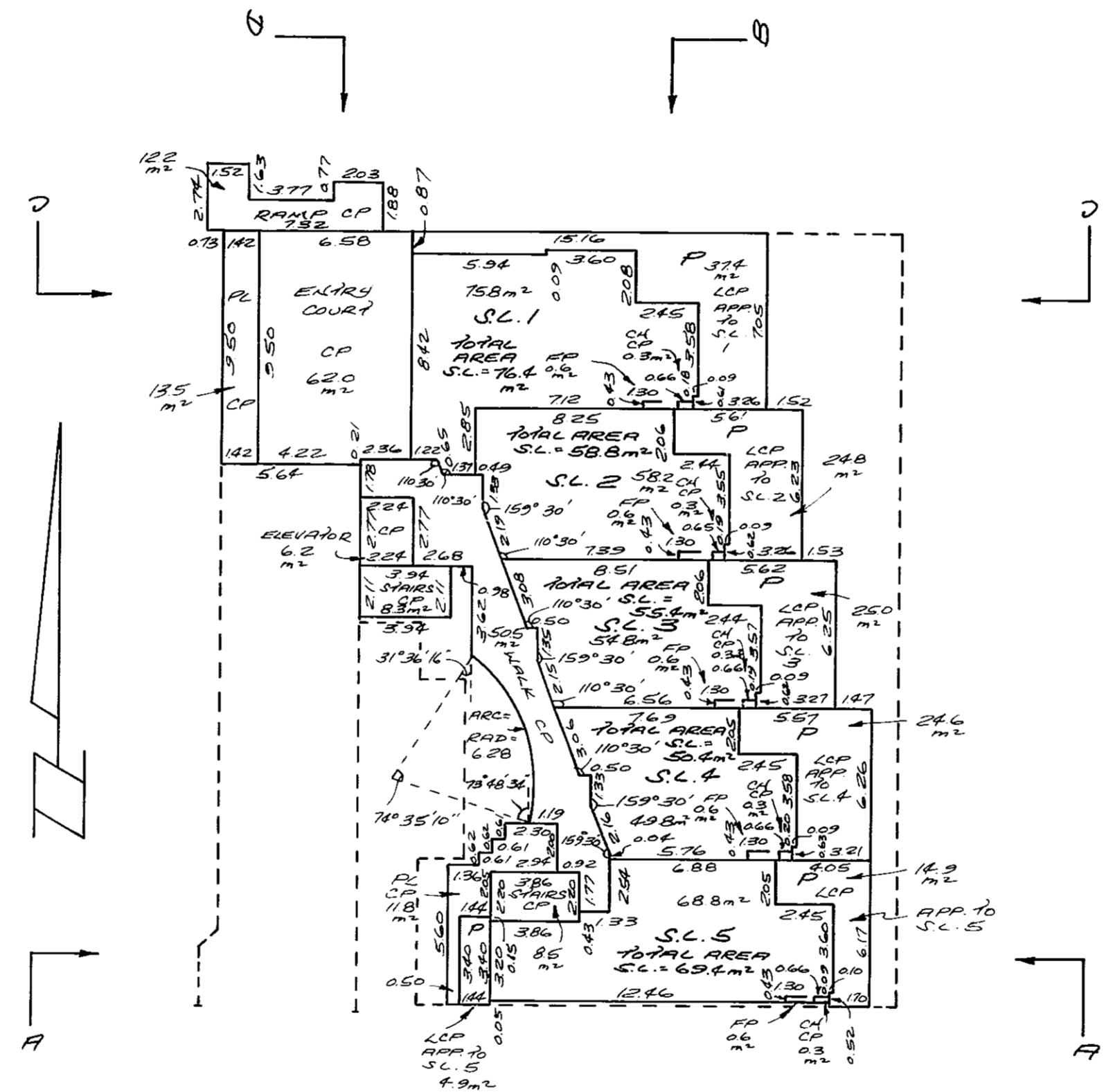

DDP  
Mar 17/08

86232

**SECOND FLOOR.  
STRATA LOTS 670-11 INCLUSIVE.**

SCALE = 1:200.  
0 5 10m

"ALL ANGLES ARE 90° OR 45° UNLESS OTHERWISE NOTED."

SHEET 6 OF 11 SHEETS  
STRATA PLAN VR 2116

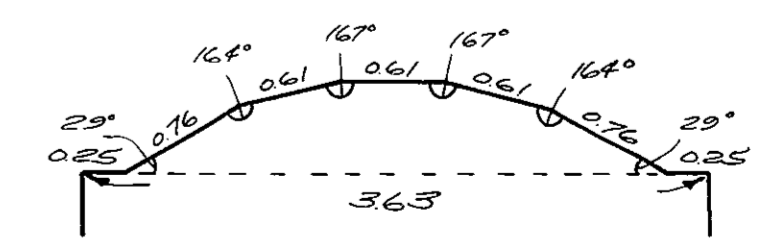
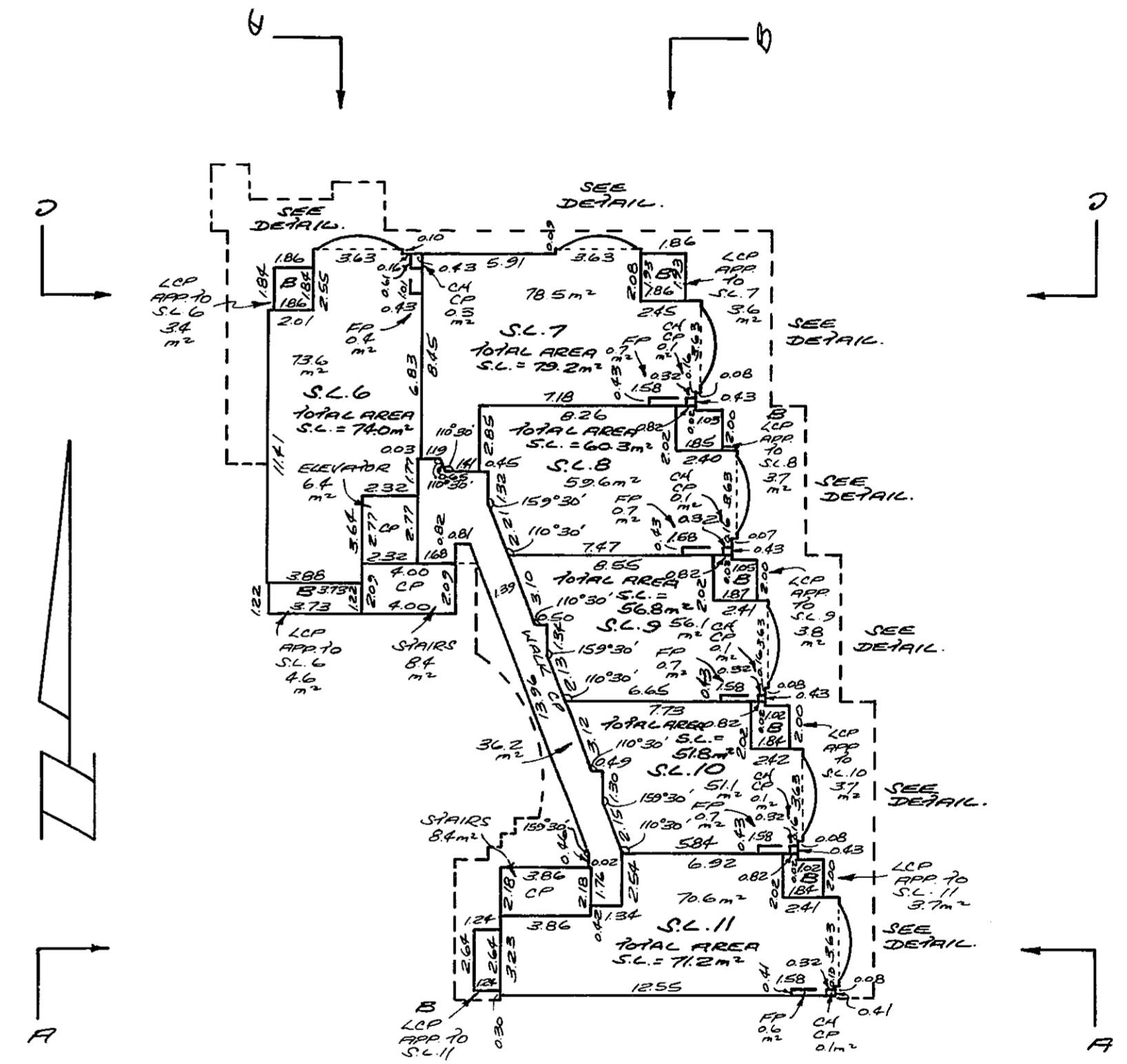

TYPICAL DETAIL:  
NOT TO SCALE.

DDP  
Mar 17/08

86232

SHEET 7 OF 11 SHEETS  
STRATA PLAN VR 2116

THIRD FLOOR.  
STRATA LOTS 12 TO 17 INCLUSIVE.

SCALE = 1:200

"ALL ANGLES ARE 30° OR 45° UNLESS OTHERWISE NOTED."

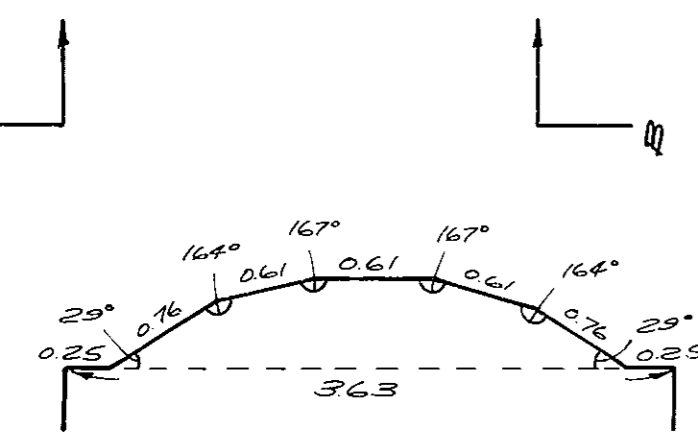
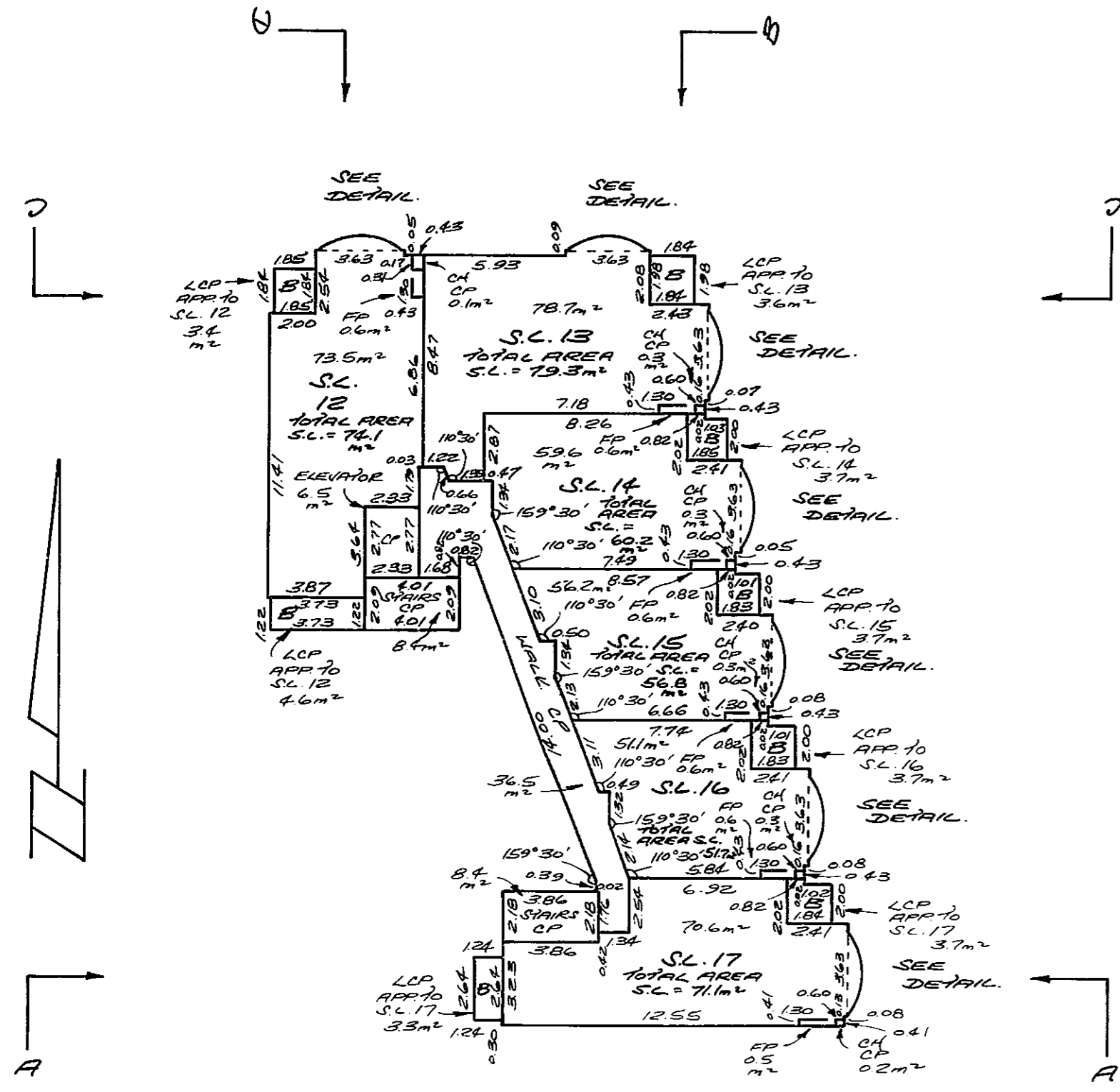

86232  
DJP  
Mar 17/08

SHEET 8 OF 11 SHEETS  
STRATA PLAN VR 2116

FOURTH FLOOR.  
STRATA LOTS 18 TO 23 INCLUSIVE.

SCALE = 1:200

"ALL ANGLES ARE 30° OR 45° UNLESS OTHERWISE NOTED."

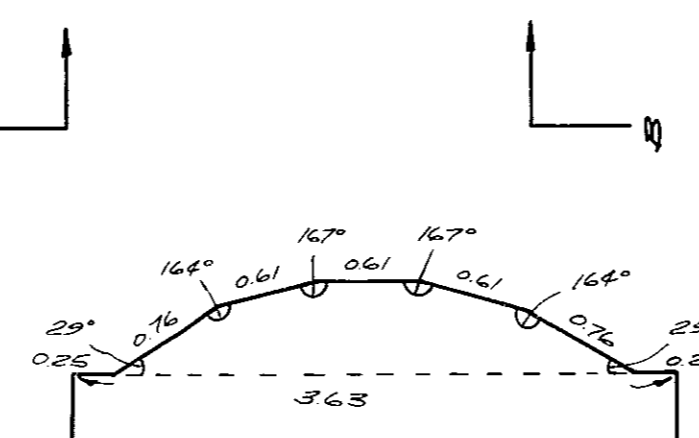
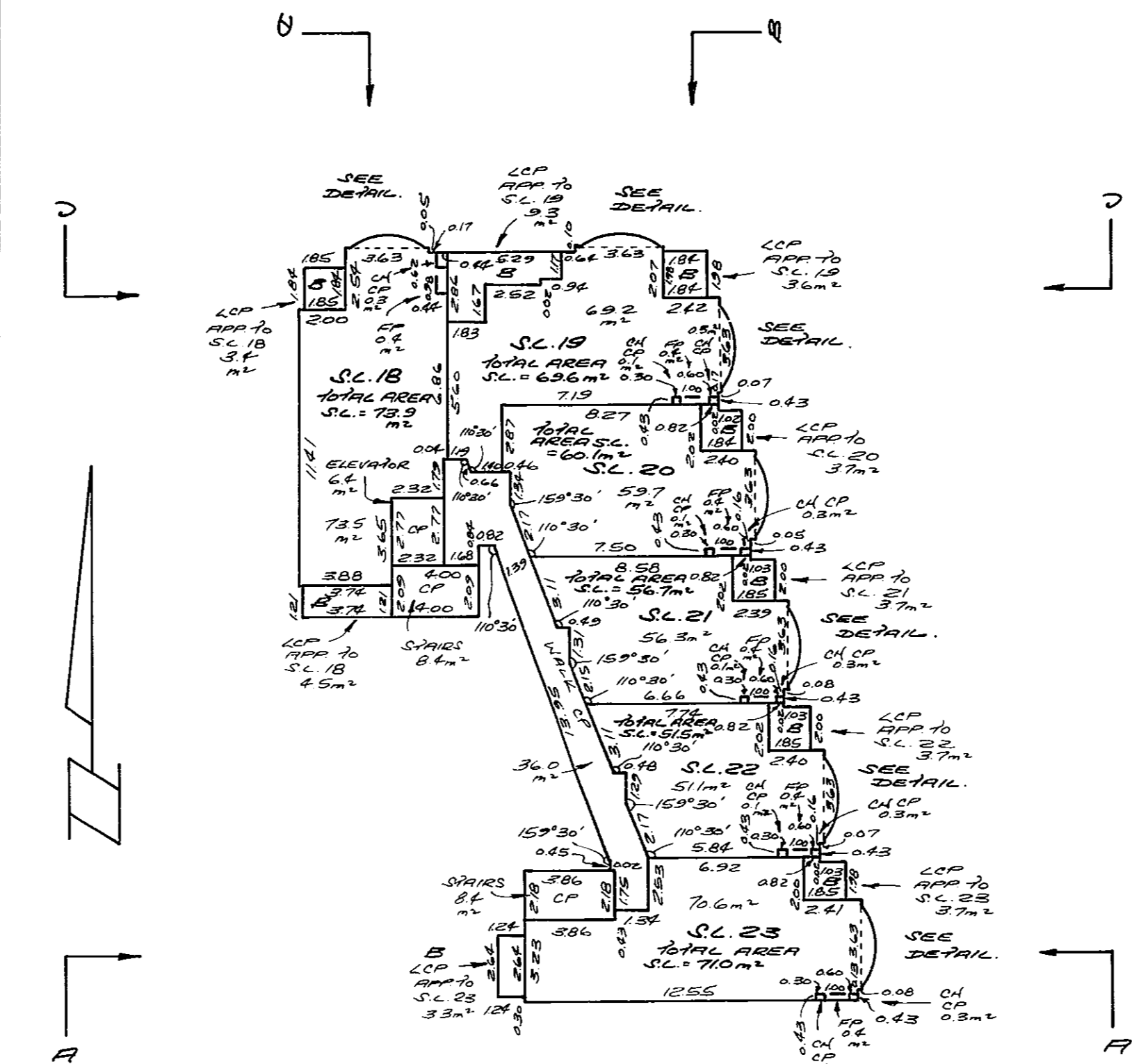

86232  
DJP  
Mar 17/08

SHEET 9 OF 11 SHEETS  
STRATA PLAN VR 2116

ROOF.  
COMMON PROPERTY.

SCALE = 1:200

"ALL ANGLES ARE 30° OR 45° UNLESS OTHERWISE NOTED."

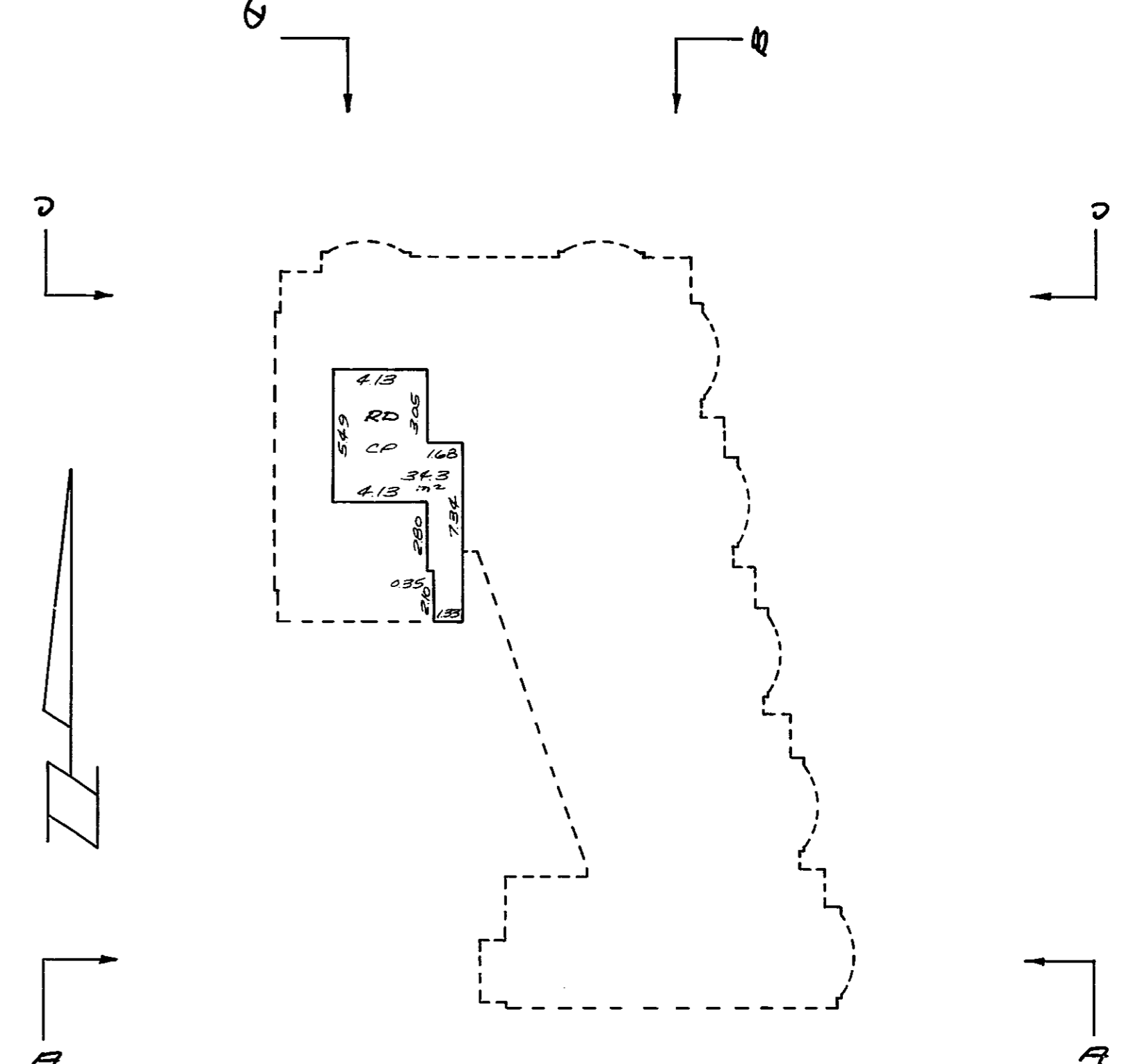

86232  
DJP  
Mar 17/08

